

IT TOOK A LOT OF WORK, BUT THIS
LATEST LINUX PATCH ENABLES SUPPORT
FOR MACHINES WITH 4,096 CPUs,
UP FROM THE OLD LIMIT OF 1,024.

DO YOU HAVE SUPPORT FOR SMOOTH
FULL-SCREEN FLASH VIDEO YET?

NO, BUT WHO USES THAT?



Multicore & Parallel Processing

Guest Lecture: Kevin Walsh

CS 3410, Spring 2011

Computer Science

Cornell University

Execution time after improvement =

$$\frac{\text{affected execution time}}{\text{amount of improvement}}$$

+ execution time unaffected

Q: How to improve system performance?

→

→

Recall: Amdahl's Law

Solution: Parallelism

Pipelining: execute multiple instructions in parallel

Q: How to get more instruction level parallelism?

A: Deeper pipeline

Pipeline depth limited by...

- max clock speed (less work per stage \Rightarrow shorter clock cycle)
- min unit of work
- dependencies, hazards / forwarding logic

Pipelining: execute multiple instructions in parallel

Q: How to get more instruction level parallelism?

A: Multiple issue pipeline

- Start multiple instructions per clock cycle in duplicate stages

Static Multiple Issue

a.k.a. Very Long Instruction Word (VLIW)

Compiler groups instructions to be issued together

- Packages them into “issue slots”

Q: How does HW detect and resolve hazards?

A: It doesn't.

→ Simple HW, assumes compiler avoids hazards

Example: Static Dual-Issue 32-bit MIPS

- Instructions come in pairs (64-bit aligned)
 - One ALU/branch instruction (or nop)
 - One load/store instruction (or nop)

Compiler scheduling for dual-issue MIPS...

```

TOP:  lw    $t0, 0($s1)           # $t0 = A[i]
      lw    $t1, 4($s1)         # $t1 = A[i+1]
      addu $t0, $t0, $s2        # add $s2
      addu $t1, $t1, $s2        # add $s2
      sw    $t0, 0($s1)         # store A[i]
      sw    $t1, 4($s1)         # store A[i+1]
      addi $s1, $s1, +8         # increment pointer
      bne  $s1, $s3, TOP        # continue if $s1!=end

```

	ALU/branch slot	Load/store slot	cycle
TOP:	nop	lw \$t0, 0(\$s1)	1
	nop	lw \$t1, 4(\$s1)	2
	addu \$t0, \$t0, \$s2	nop	3
	addu \$t1, \$t1, \$s2	sw \$t0, 0(\$s1)	4
	addi \$s1, \$s1, +8	sw \$t1, 4(\$s1)	5
	bne \$s1, \$s3, TOP	nop	6

Compiler scheduling for dual-issue MIPS...

```

lw    $t0, 0($s1)           # load A
addi  $t0, $t0, +1         # increment A
sw    $t0, 0($s1)           # store A
lw    $t0, 0($s2)           # load B
addi  $t0, $t0, +1         # increment B
sw    $t0, 0($s2)           # store B

```

ALU/branch slot	Load/store slot	cycle
nop	lw \$t0, 0(\$s1)	1
nop	nop	2
addi \$t0, \$t0, +1	nop	3
nop	sw \$t0, 0(\$s1)	4
nop	lw \$t0, 0(\$s2)	5
nop	nop	6
addi \$t0, \$t0, +1	nop	7
nop	sw \$t0, 0(\$s2)	8

Dynamic Multiple Issue

a.k.a. SuperScalar Processor (c.f. Intel)

- CPU examines instruction stream and chooses multiple instructions to issue each cycle
- Compiler can help by reordering instructions....
- ... but CPU is responsible for resolving hazards

Even better: Speculation/Out-of-order Execution

- Execute instructions as early as possible
- Aggressive register renaming
- Guess results of branches, loads, etc.
- Roll back if guesses were wrong
- Don't commit results until all previous insts. are retired

Q: Does multiple issue / ILP work?

A: Kind of... but not as much as we'd like

Limiting factors?

- Programs dependencies
- Hard to detect dependencies → be conservative
 - e.g. Pointer Aliasing: `A[0] += 1; B[0] *= 2;`
- Hard to expose parallelism
 - Can only issue a few instructions ahead of PC
- Structural limits
 - Memory delays and limited bandwidth
- Hard to keep pipelines full

Q: Does multiple issue / ILP cost much?

A: Yes.

→ Dynamic issue and speculation requires power

CPU	Year	Clock Rate	Pipeline Stages	Issue width	Out-of-order/ Speculation	Cores	Power
i486	1989	25MHz	5	1	No	1	5W
Pentium	1993	66MHz	5	2	No	1	10W
Pentium Pro	1997	200MHz	10	3	Yes	1	29W
P4 Willamette	2001	2000MHz	22	3	Yes	1	75W
UltraSparc III	2003	1950MHz	14	4	No	1	90W
P4 Prescott	2004	3600MHz	31	3	Yes	1	103W
Core	2006	2930MHz	14	4	Yes	2	75W
UltraSparc T1	2005	1200MHz	6	1	No	8	70W

→ Multiple simpler cores may be better?

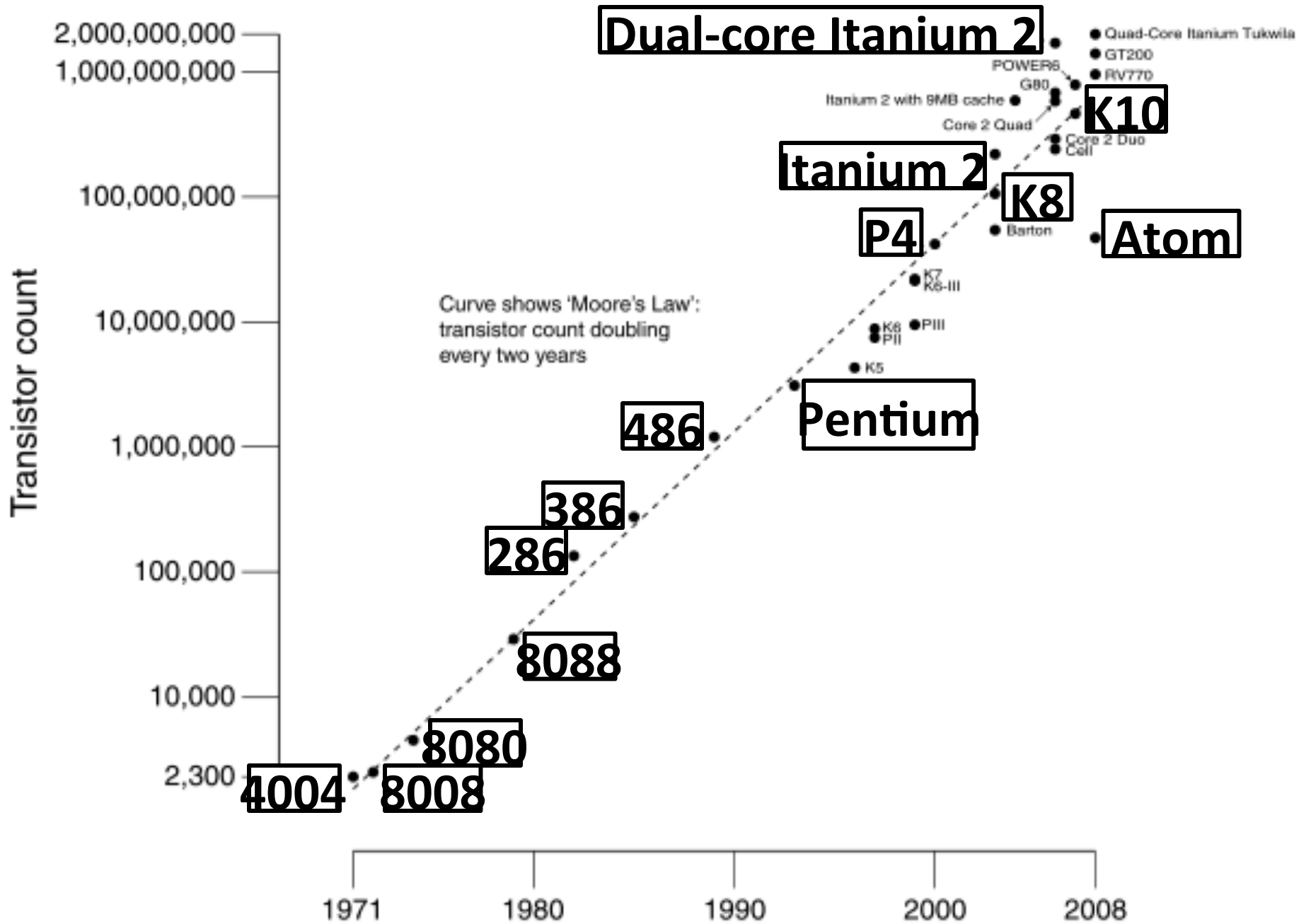

Moore's law

- A law about transistors
- Smaller means more transistors per die
- And smaller means faster too

But: Power consumption growing too...

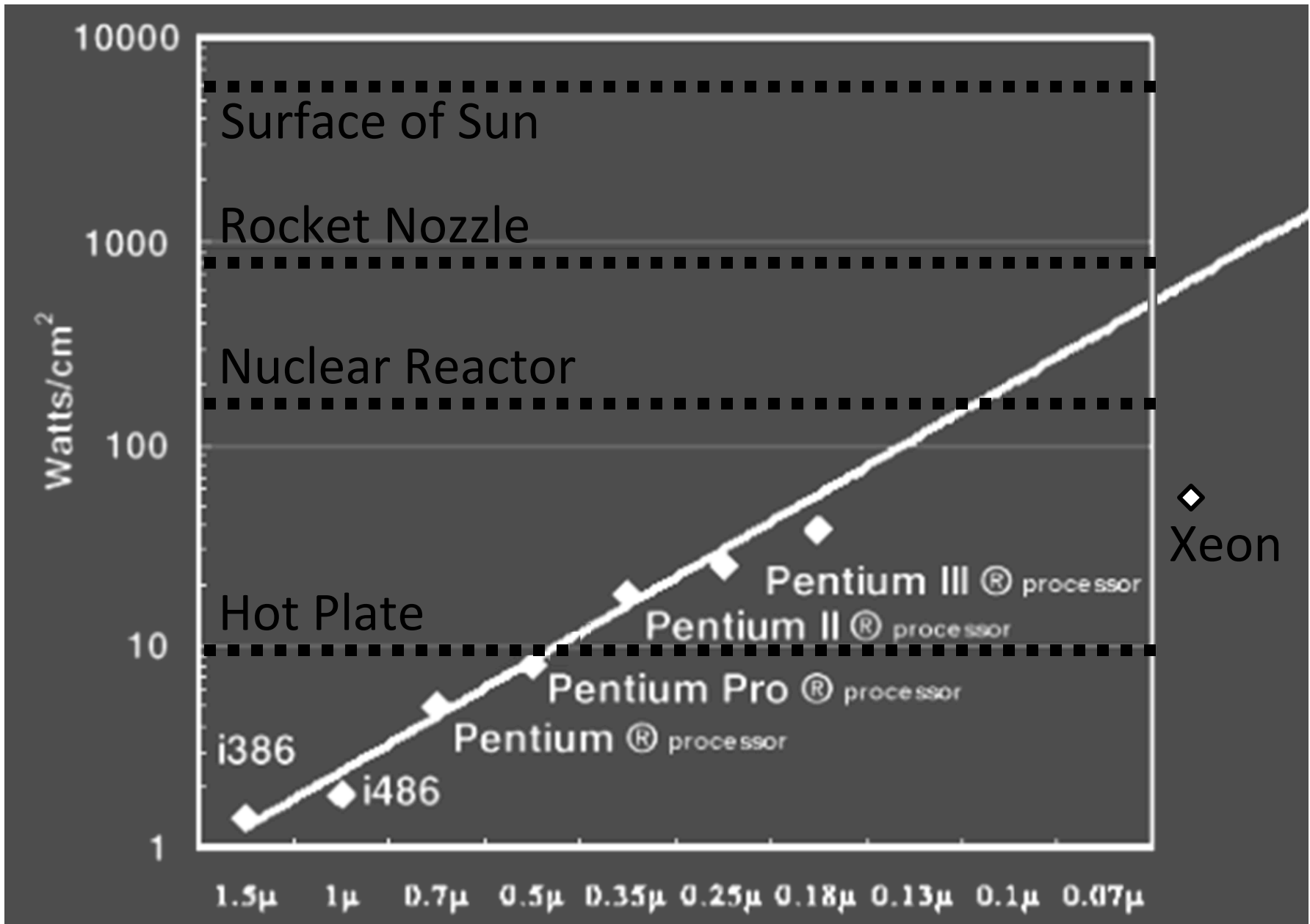

Power = capacitance * voltage² * frequency

In practice: Power \sim voltage³

Reducing voltage helps (a lot)

... so does reducing clock speed

Better cooling helps

The power wall

- We can't reduce voltage further
- We can't remove more heat

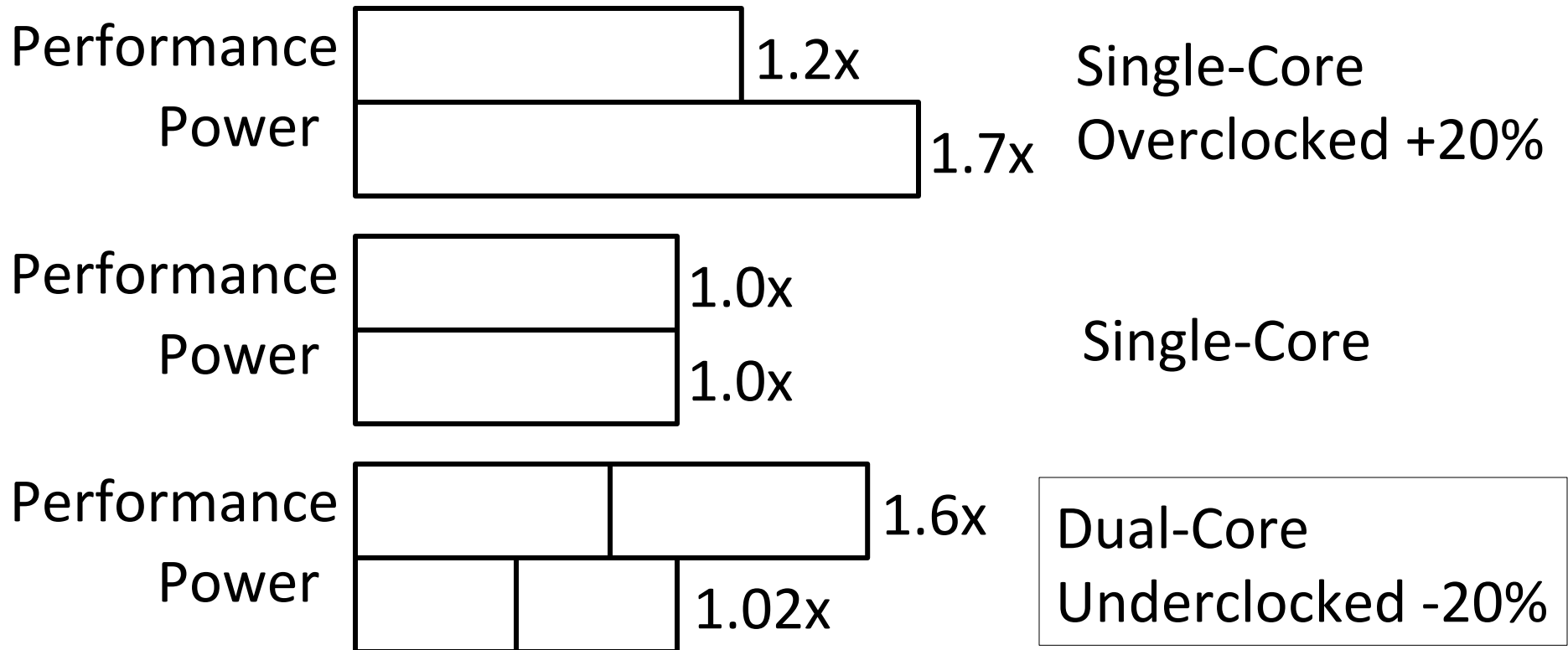

AMD Barcelona Quad-Core: 4 processor cores

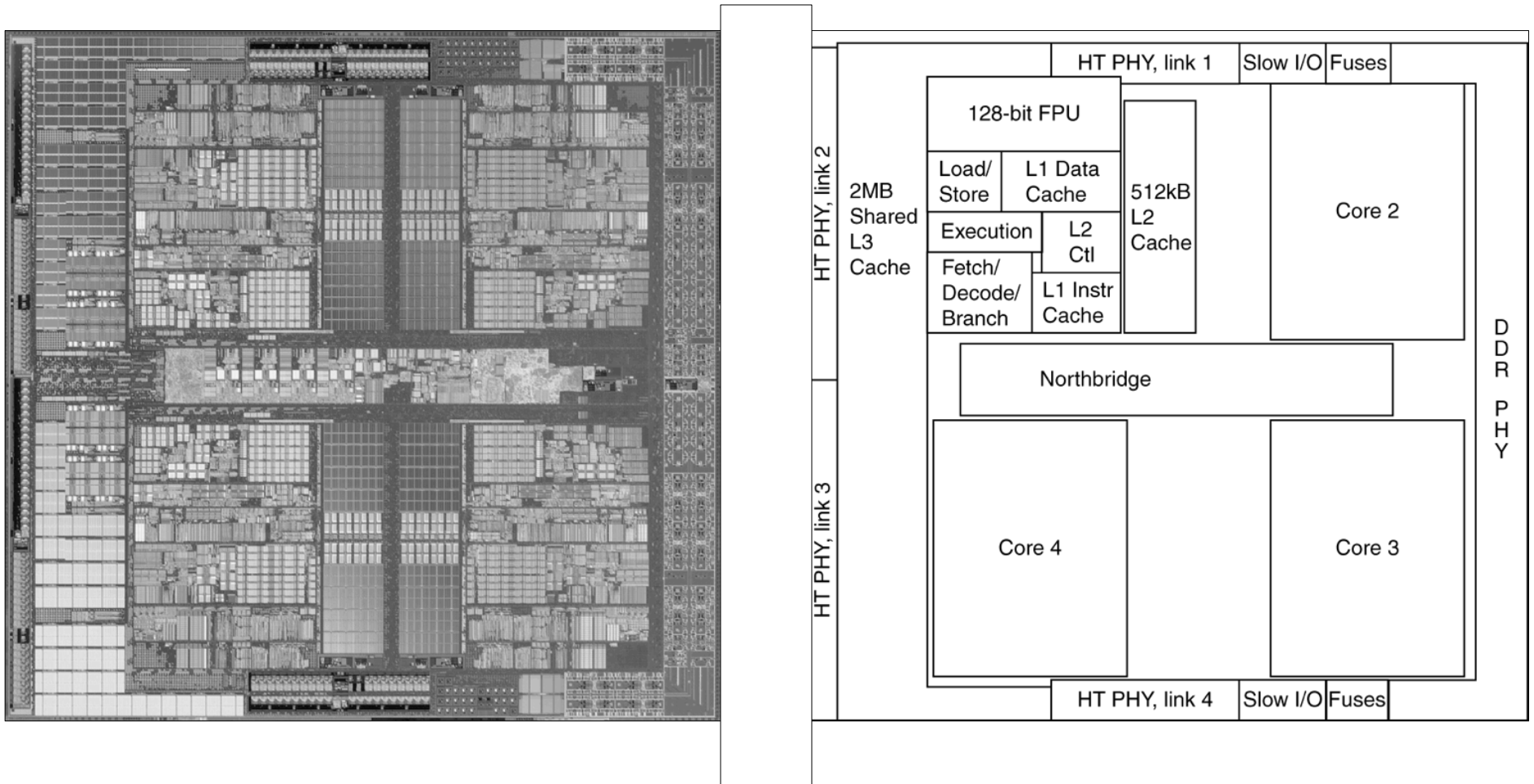

Intel Nehalem Hex-Core

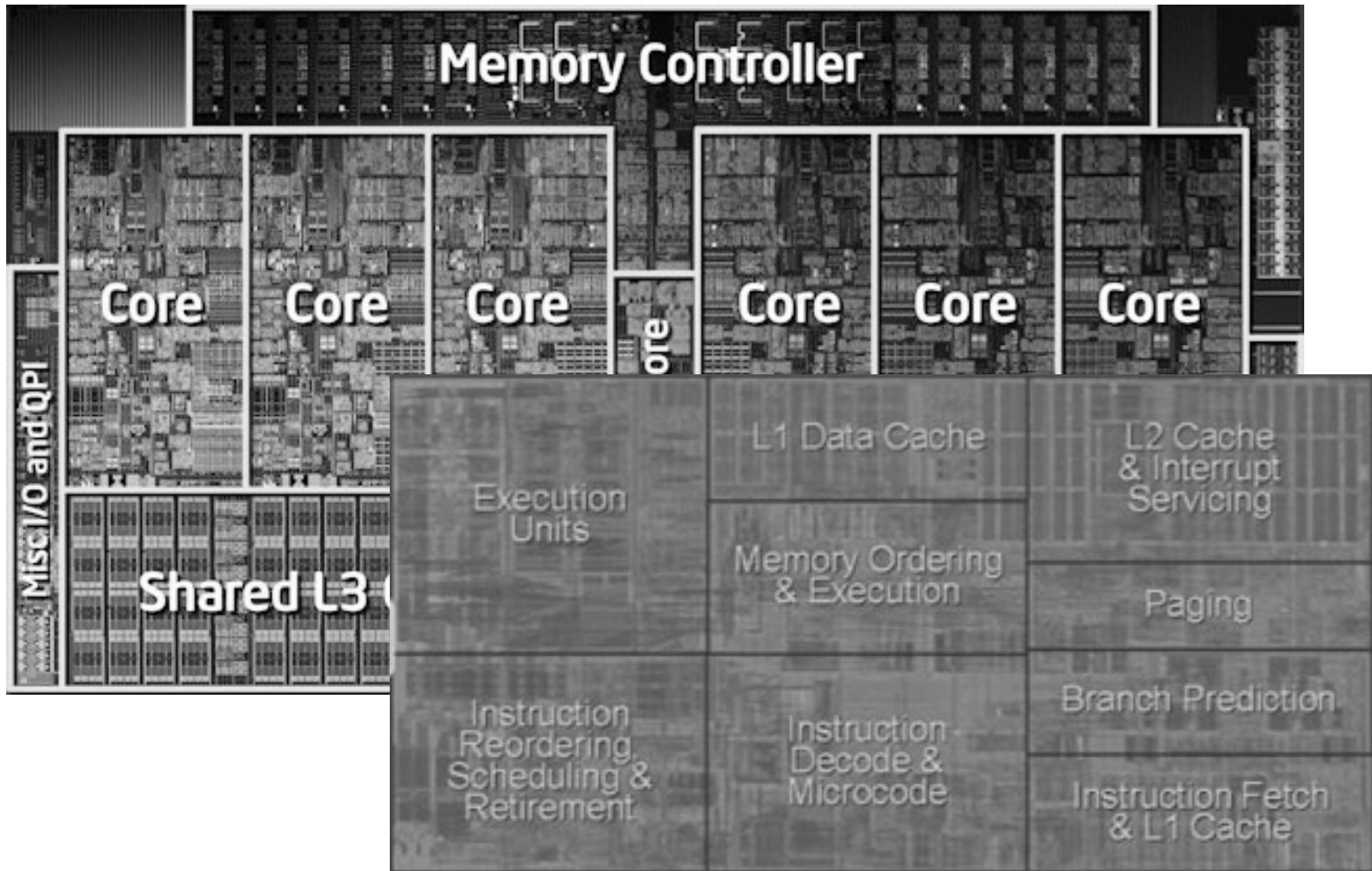

Multi-Core vs. Multi-Issue vs. HT

Programs:

Num. Pipelines:

Pipeline Width:

Hyperthreads (Intel)

- Illusion of multiple cores on a single core
- Easy to keep HT pipelines full + share functional units

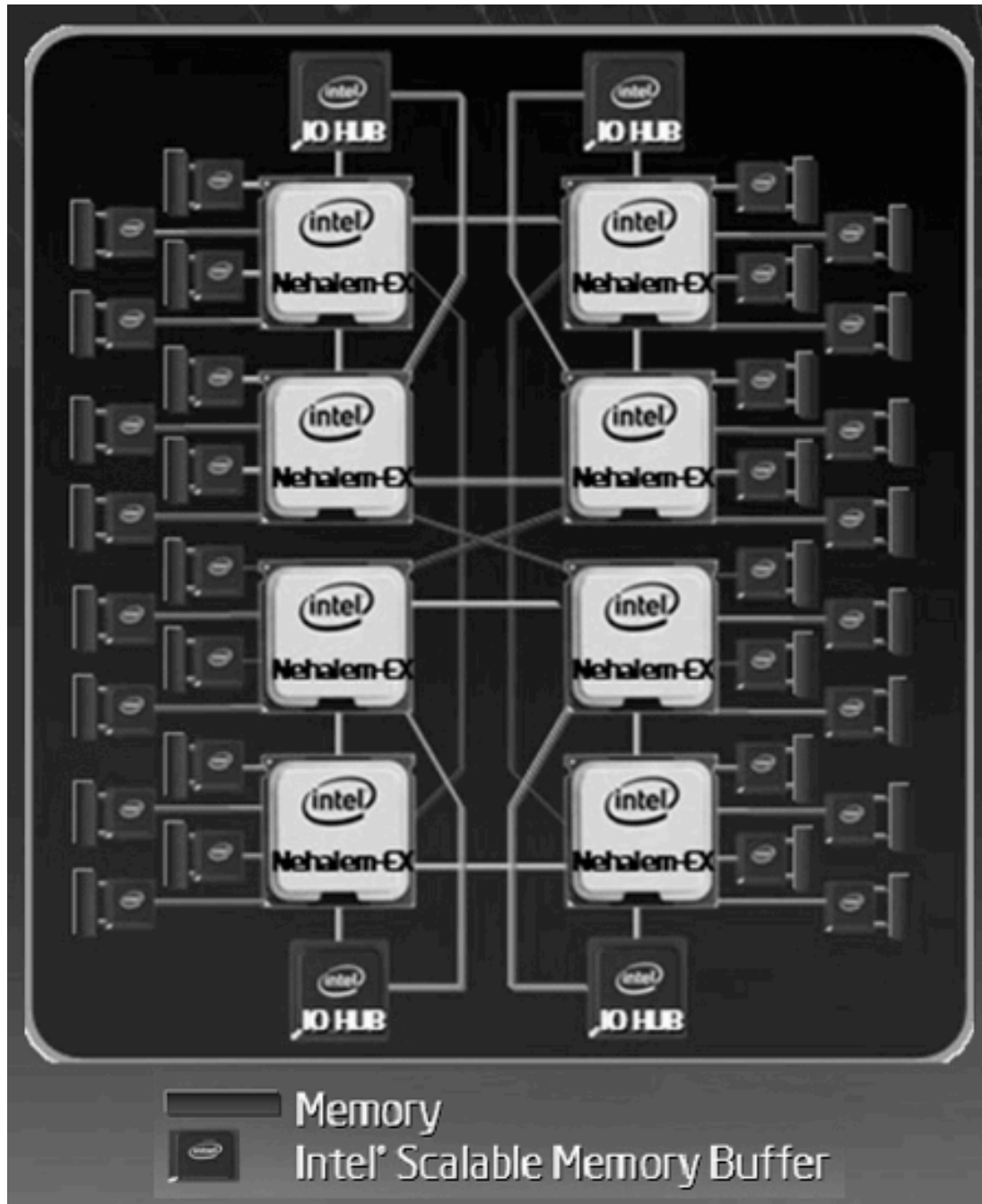

Q: So lets just all use multicore from now on!

A: Software must be written as parallel program

Multicore difficulties

- Partitioning work
- Coordination & synchronization
- Communications overhead
- Balancing load over cores
- How do you write parallel programs?
 - ... without knowing exact underlying architecture?

Partition work so all cores have something to do



Load Balancing

Need to partition so all cores are actually working

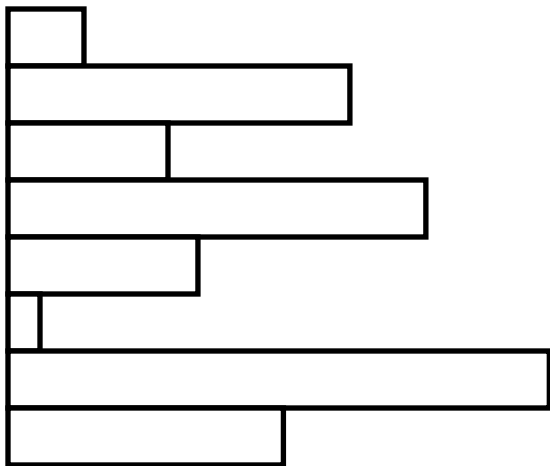

If tasks have a serial part and a parallel part...

Example:

step 1: divide input data into n pieces

step 2: do work on each piece

step 3: combine all results

Recall: Amdahl's Law

As number of cores increases ...

- time to execute parallel part?
- time to execute serial part?

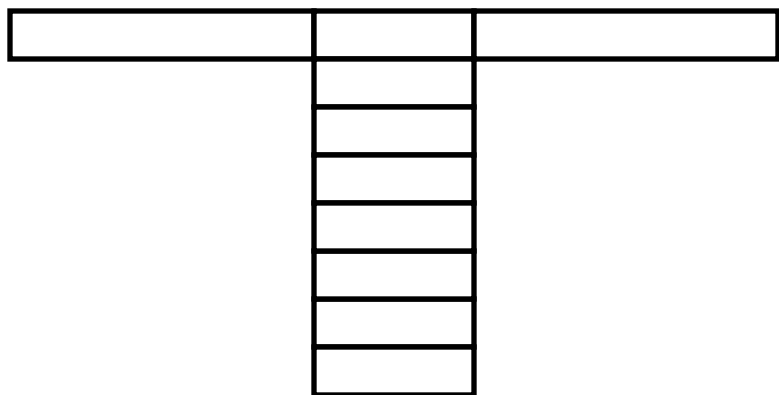

Q: So lets just all use multicore from now on!

A: Software must be written as parallel program

Multicore difficulties

- Partitioning work
- Coordination & synchronization
- Communications overhead
- Balancing load over cores
- How do you write parallel programs?
 - ... without knowing exact underlying architecture?