

Cayuga Heights Elementary School 5th grade math club

Problems for 29 January 2016 : Area and Volume

1. If every cube is 2cm x 2cm x 2cm, what is the surface area of this shape?

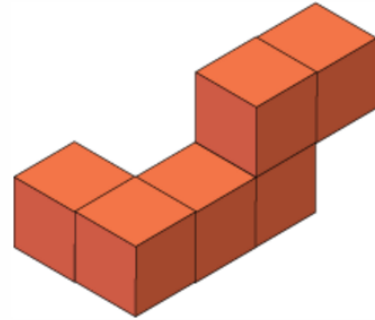

2. If the side of every cube is 3cm, what is the volume of each of these two shapes?

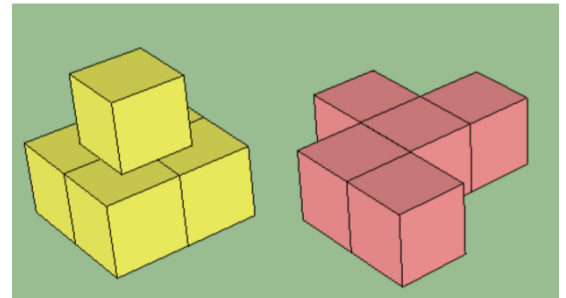

3. What is the surface area of each of the shapes?

4. Two square gardens are each 10m by 10m. They are enclosed by a sidewalk of width 1m. There is also a shared sidewalk of width 1m between gardens (as shown). Find the total area, in square meters, of the sidewalks.

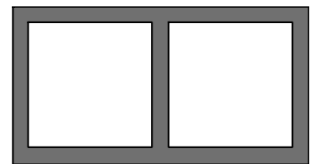

5. If every side of every rectangle is a whole number, what is the area of the fourth rectangle?

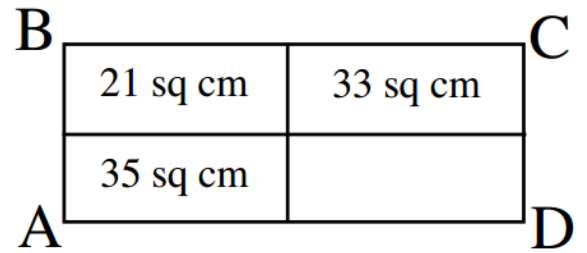

6. Two congruent right-angle triangles fit into the rectangle. What is the area in orange?

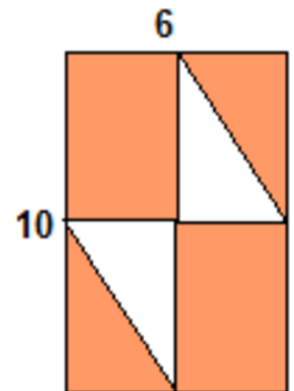

7. In this square, the length of the line AD is 4 cm. Point O is the center of the square and point E is in the middle of the line CD. What is the area of the shaded part of the square?

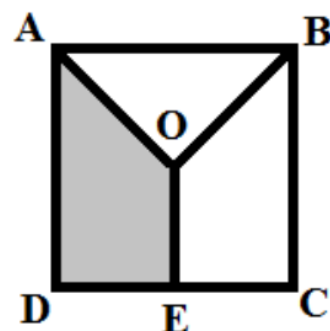

8. A metal sheet is 30 cm x 40 cm. to make an open top box, the corners are cut off. Each piece cut off is 2cm x 2cm. The four sides are folded to make a box, what is the surface area of this box?



9. What is the volume of this box?

10. Now, with the same size metal sheet, the cut off 4cm x 4cm corners. What is the surface area and what is the volume? How do they compare to the surface area and volume of questions 8 and 9? Why?

11. Find the area of the following shapes:

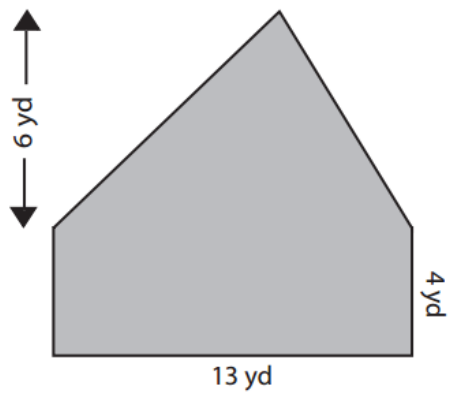
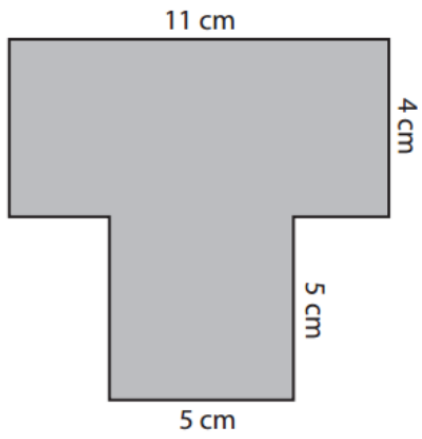
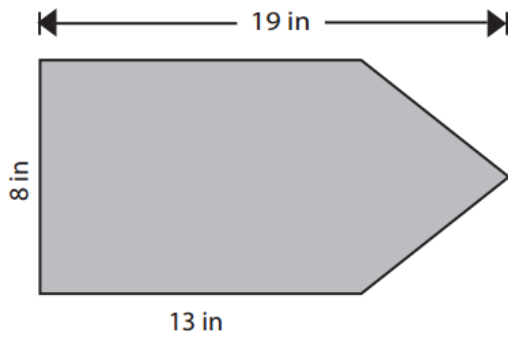

12. Jo made a cube from some smaller cubes. She painted some of the faces of the large cube, and then took it apart again. She counted her cubes and noticed that 45 cubes had no paint on them at all. How many small cubes did Jo use to make her large cube and how many faces did she paint?

13. Dan made a cube the same size as Jo's large cube, and also painted some of the faces. How many unpainted cubes might Dan have ended up with?