

Universally Composable Security with Global Setup

Ran Canetti* Yevgeniy Dodis† Rafael Pass‡ Shabsi Walfish§

November 20, 2006

Abstract

Cryptographic protocols are often designed and analyzed under some *trusted setup* assumptions, namely in settings where the participants have access to global information that is trusted to have some basic security properties. However, current modeling of security in the presence of such setup falls short of providing the expected security guarantees. A quintessential example of this phenomenon is the *deniability* concern: there exist natural protocols that meet the strongest known composable security notions, and are still vulnerable to bad interactions with rogue protocols that use the same setup.

We extend the notion of universally composable (UC) security in a way that re-establishes its original intuitive guarantee even for protocols that use globally available setup. The new formulation prevents bad interactions even with adaptively chosen protocols that use the same setup. In particular, it guarantees deniability. While for protocols that use no setup the proposed requirements are the same as in traditional UC security, for protocols that use global setup the proposed requirements are significantly stronger. In fact, realizing Zero Knowledge or commitment becomes provably impossible, even in the Common Reference String model. Still, we propose reasonable alternative setup assumptions and protocols that allow realizing practically any cryptographic task under standard hardness assumptions *even against adaptive corruptions*.

*canetti@csail.mit.edu. IBM Research, 19 Skyline Dr., Hawthorne, NY 10532 USA.

†dodis@cs.nyu.edu. New York University, Department of Computer Science, 251 Mercer St., New York, NY 10012 USA.

‡rafael@cs.cornell.edu. Cornell University, Department of Computer Science, Ithaca, NY 14853 USA.

§walfish@cs.nyu.edu. New York University, Department of Computer Science, 251 Mercer St., New York, NY 10012 USA.

Contents

1	Introduction	2
2	Generalized UC Security	7
2.1	Overview of Generalized UC Security	7
2.2	Details of the Generalized UC Framework	11
2.2.1	Basic UC Security	13
2.2.2	Generalized UC Security	15
2.2.3	Externalized UC Security	17
2.2.4	Equivalence of GUC to EUC and a generalized UC theorem	18
3	Insufficiency of the Global CRS Model	22
3.1	Impossibility of GUC-realizing \mathcal{F}_{com} in the $\bar{\mathcal{G}}_{crs}$ model	22
3.2	Deniability and Full Simulatability	25
4	Fully Simulatable General Computation	26
4.1	The KRK Model	27
4.2	The Augmented CRS Model	28
5	GUC-Realizing \mathcal{F}_{com} using the $\bar{\mathcal{G}}_{acrs}$ Global Setup	30
5.1	High-level description of the protocol	31
5.2	Identity-based Trapdoor Commitments	33
5.2.1	Augmented Σ -Protocols	34
5.2.2	An IBTC from Signature Schemes with Augmented Σ -Protocols	36
5.2.3	Signature Schemes with Augmented Σ -Protocols	37
5.3	Dense OT-PRC Secure Encryption	37
5.4	Details and Design of Protocol UAIBC	38
5.5	Security Proof for Protocol UAIBC	41
6	Acknowledgments	45

1 Introduction

The trusted party paradigm is a fundamental methodology for defining security of cryptographic protocols. The basic idea (which originates in [26]) is to say that a protocol securely realizes a given computational task if running the protocol amounts to “emulating” an ideal process where all parties secretly hand their inputs to an imaginary “trusted party” who locally computes the desired outputs and hands them back to the parties. One main potential advantage of this paradigm is its strong “built in composability” property: The fact that a protocol π emulates a certain trusted party \mathcal{F} can be naturally interpreted as implying that any system that includes calls to protocol π should, in principle, behave the same if the calls to π were replaced by ideal calls to the trusted party \mathcal{F} .

Several formalizations of the above intuitive idea exist, e.g. [24, 31, 2, 10, 21, 36, 11, 35]. These formalizations vary in their rigor, expressibility, generality and restrictiveness, as well as security and composability guarantees. However, one point which no existing formalism seems to handle in a fully satisfactory way is the security requirements in the presence of “global trusted setup assumptions”, such as a public-key infrastructure (PKI) or a common reference string (CRS), where all parties are assumed to have access to some global information that is trusted to have certain properties. Indeed, as pointed out in [33], the intuitive guarantee that “running π has the same effect as having access to the trusted party” no longer holds.

As a first indication of this fact, consider the “deniability” concern, namely, allowing party A to interact with party B in a way that prevents B from later “convincing” a third party C that the interaction took place. Indeed, if A and B interact via an idealized “trusted party” that communicates only with A and B then deniability is guaranteed in a perfect, idealized way. Thus, intuitively, if A and B interact via a protocol that emulates the trusted party, then deniability should hold just the same. When the protocol in question uses no global setup, this intuition works, in the sense that emulating a trusted party (in most existing formalisms) automatically implies deniability. However, when global setup is used, this is no longer the case: There are protocols that emulate such a trusted party but do *not* guarantee deniability.

For instance, consider the case of Zero-Knowledge protocols, *i.e.* protocols that emulate the trusted party for the “Zero-Knowledge functionality”: Zero-Knowledge protocols in the plain model are inherently deniable, but most Zero-Knowledge protocols in the CRS model are completely *undeniable* whenever the reference string is public knowledge (see [33]). Similarly, most authentication protocols (*i.e.*, most protocols that emulate the trusted party that provides ideally authenticated communication) that use public key infrastructure are not deniable, in spite of the fact that ideal authenticated communication via a trusted party is deniable.

One might think that this “lack of deniability” arises only when the composability guarantees provided by the security model are weak. However, even very strong notions composability do not automatically suffice to ensure deniability in the presence of global setup. For example, consider the Universal Composability (UC) security model of [11], which aims to achieve the following, very strong composability guarantee:

A UC-secure protocol π implementing a trusted party \mathcal{F} does not affect any other protocols more than \mathcal{F} does — even when protocols running concurrently with π are maliciously and adversarially constructed.

When \mathcal{F} is the Zero-Knowledge functionality, this property would seem to guarantee that deniability will hold even when the protocol π is used in an arbitrary manner. Yet, even UC-secure ZK protocols that use a CRS are *not* deniable whenever the reference string is globally available. This demonstrates that the UC notion, in its present formulation, does *not* protect a secure protocol π from a protocol π' that was maliciously designed to interact badly with π , in the case where π' can use the *same setup* as π .

Deniability is not the only concern that remains un-captured in the present formulation of security in the CRS model. For instance, the protocol in [16] for realizing the single-instance commitment functionality becomes *malleable* as soon as *two* instances use the same reference string (indeed, to avoid this weakness a more involved protocol was developed, where multiple commitments can explicitly use the same reference string in a specific way). Note that here, a UC-secure protocol can even affect the security of another UC secure protocol if both protocols make reference to the same setup.

This situation is disturbing, especially in light of the fact that *some* form of setup is often *essential* for cryptographic solutions. For instance, most traditional two-party tasks cannot be UC-realized with no setup [16, 11, 17], and authenticated communication is impossible without some sort of setup [13]. Furthermore, providing a *globally available* setup that can be used throughout the system is by far the most realistic and convenient way to provide setup.

A new formalism. This work addresses the question of how to formalize the trusted-party definitional paradigm in a way that preserves its intuitive appeal even for those protocols that use globally available setup. Specifically, our first contribution is to generalize the UC framework to deal with global setup, so as to explicitly guarantee that the original meaning of “emulating a trusted party” is preserved, even when the analyzed protocol is using the *same setup* as other protocols that may be maliciously and adaptively designed to interact badly with it. In particular, the new formalism called simply generalized UC (GUC) security guarantees deniability and non-malleability even in the presence of global setup. Informally,

A GUC-Secure protocol π implementing a trusted party \mathcal{F} using some global setup does not affect any other protocols more than \mathcal{F} does — even when protocols running concurrently with π are maliciously and adversarially constructed, and even when all protocols use the same global setup.

In a nutshell, the new modeling proceeds as follows. Recall that the UC framework models setup as a “trusted subroutine” of the protocol that uses the setup. This implicitly means that the setup is local to the protocol instance using it, and cannot be safely used by any other protocol instance. That modeling, while mathematically sound, certainly does not capture the real-world phenomenon of setup that is set in advance and publicly known throughout the system. The UC with joint state theorem (“JUC Theorem”) of [19] allows several instances of specifically-designed protocols to use the same setup, but it too does not capture the case of public setup that can be used by arbitrary different protocols at the same time.

To adequately capture global setup our new formalism models the setup as an additional (trusted) entity that interacts not only with the parties running the protocol, but also with other parties (or, in other words, with the external environment). This in particular means that the setup entity exists not only as part of the protocol execution, but also in the *ideal process*, where the protocol is replaced by the trusted party. For instance, while in the current UC framework the CRS model is captured

as a trusted setup entity that gives the reference string only to the adversary and the parties running the actual protocol instance, here the reference string is globally available, i.e. the trusted setup entity also gives the reference string directly to other parties and the external environment. Technically, the effect of this modeling is that now the simulator (namely, the adversary in the ideal process) cannot choose the reference string or know related trapdoor information.

In a way, proofs of security in the new modeling, even with setup, are reminiscent of the proofs of security without setup, in the sense that the only freedom enjoyed by the simulator is to control the local random choices of the uncorrupted parties. For this reason we often informally say that GUC-secure protocols that use only globally available setup are “fully simulatable”. We also remark that this modeling is in line with the “non-programmable CRS model” in [33].

One might thus suspect that achieving GUC-security “collapses” down to UC-security *without any setup* (and its severe limitations). Indeed, as a first result we extend the argument of [16] to show that no two-party protocol can GUC-realize the ideal commitment functionality \mathcal{F}_{com} (namely, emulate the trusted party that runs the code of \mathcal{F}_{com} according to the new notion), *even in the CRS model, or in fact with any global setup that simply provides public information*. On the one hand this result is reassuring, since it means that those deniable and malleable protocols that are secure in the (old) CRS model can no longer be secure according to the new notion. On the other hand, this result brings forth the question of whether there exist protocols for commitment (or other interesting primitives) that meet the new notion under *any* reasonable setup assumption. Indeed, the analyses of all existing UC-secure commitment protocols seem to use in an essential way the fact that the simulator has control over the value of the setup information.

New setup and constructions. Perhaps surprisingly, we answer the realizability question in the affirmative, in a strong sense. Recall that our impossibility result shows that a GUC protocol for the commitment functionality must rely on a setup that provides the parties with some *private* information. We consider two alternative setup models which provide such private information in a *minimal* way, and show how to GUC-realize practically any ideal functionality in any one of the two models.

The first setup model is reminiscent of the “key registration with knowledge (KRK)” setup from [5], where each party registers a public key with some trusted authority in a way that guarantees that the party can access the corresponding secret key. However, in contrast to [5] where the scope of a registered key is only a single protocol instance (or, alternatively, several instances of specifically designed protocols), here the registration is done once per party throughout the lifetime of the system, and the public key can be used in all instances of all the protocols that the party might run. In particular, it is directly accessible by the external environment.

We first observe that one of the [5] protocols for realizing \mathcal{F}_{com} in the KRK model can be shown to satisfy the new notion, even with the global KRK setup, as long as the adversary is limited to *non-adaptive* party corruptions. (As demonstrated in [18], realizing \mathcal{F}_{com} suffices for realizing *any* “well-formed” multi-party functionality.) However, when adaptive party corruptions are allowed, and the adversary can observe the past internal data of corrupted parties, this protocol becomes insecure. In fact, the problem seems inherent, since the adversary is now able to eventually see *all* the secret keys in the system, even those of parties that were uncorrupted when the computation took place.

Still, we devise a new protocol that realizes \mathcal{F}_{com} in the KRK model even in the presence of adaptive party corruptions, and without any need for data erasures. The high level idea is to use

the [16] commitment scheme with a new CRS that is chosen by the parties per commitment. The protocol for choosing the CRS will make use of the public keys held by the parties, in a way that allows the overall simulation to go through even when the same public keys are used in multiple instances of the CRS-generation protocol. Interestingly, our construction does not realize a CRS that is “strong” enough for the original analysis to go through. Instead, we provide a “weaker” CRS, and provide a significantly more elaborate analysis. The protocol is similar in spirit to the coin-tossing protocol of [20], in that it allows the generated random string to have different properties depending on which parties are corrupted. Even so, their protocol is not adaptively secure in our model.

Augmented CRS. Next we formulate a new setup assumption, called “augmented CRS (ACRS)” and demonstrate how to GUC-realize \mathcal{F}_{com} in the ACRS model, in the presence of adaptive adversaries. As the name suggests, ACRS is reminiscent of the CRS setup, but is somewhat augmented so as to circumvent the impossibility result for plain CRS. That is, as in the CRS setup, all parties have access to a short reference string that is taken from a pre-determined distribution. In addition, the ACRS setup allows corrupted parties to obtain “personalized” secret keys that are derived from the reference string, their public identities, and some “global secret” that’s related to the public string and remains unknown. It is stressed that *only corrupted parties* may obtain their secret keys. This means that the protocol may not include instructions that require knowledge of the secret keys and, therefore, the protocol interface in the ACRS setup is identical to that of the CRS setup.

The main tool in our protocol for realizing \mathcal{F}_{com} in the ACRS model is a new *identity-based trapdoor commitment (IBTC)* protocol. IBTC protocols are constructed in [1, 37], in the Random Oracle model. Here we provide a construction in the standard model based on one way functions. The construction is secure against adaptive corruptions, and is based on the Feige construction of commitment from Sigma protocols [22], where the committer runs the *simulator* of the Sigma protocol.

Realizing the setup assumptions. “Real world implementations” of the ACRS and KRK setups can involve a trusted entity (say, a “post office”) that only publicizes the public value. The trusted entity will also agree to provide the secret keys to the corresponding parties upon request, with the understanding that once a party gets hold of its key then it alone is responsible to safeguard it and use it appropriately (much as in the case of standard PKI). In light of the impossibility of a completely non-interactive setup (CRS), this seems to be a minimal “interactiveness” requirement from the trusted entity.

Another unique feature of our commitment protocol is that it guarantees security even if the “global secret” is compromised, as long as this happens *after the commitment phase is completed*. In other words, in order to compromise the overall security, the trusted party has to be *actively malicious during the commitment phase*. This point further reduces the trust in the real-world entity that provides the setup.

Despite the fact that the trusted entity need not be constantly available, and need not remain trustworthy in the long term, it may still seem difficult to provide such an interactive entity in many real-world settings. Although it is impossible to achieve true GUC security with a mere CRS, we observe that the protocols analyzed here do satisfy some notion of security even if the setup entity remains non-interactive (*i.e.* when our ACRS setup functionality is instead collapsed to a standard CRS setup). In fact, although we do not formally prove a separation, protocols proven secure in the ACRS model seem intuitively *more secure* than those of [16, 18] *even when used in the CRS*

model! Essentially, in order to simulate information that could be obtained via a real attack on the protocols of [16, 18], knowledge of a “global trapdoor” is required. This knowledge enables the simulator to break the security *of all parties* (including their privacy). On the other hand, simulating the information obtained by real attacks on protocols that are proven secure in the ACRS model merely requires some specific “identity-based trapdoors”. These specific trapdoors used by the simulate allow it to break only the security *of corrupt parties who deviate from the protocol*. Of course, when using a CRS setup in “real life” none of these trapdoors are available to anyone, so one cannot actually simulate information obtained by an attacker. Nevertheless, it seems that the actual advantage gained by an attack which *could* have been simulated using the more minimal resources required by protocol simulators in the ACRS model (*i.e.* the ability to violate the security only of corrupt parties, as opposed to all parties) is intuitively smaller.

A New Composition Theorem. We present two formulations of GUC security: one formulation is more general and more “intuitively adequate”, while the other is simpler and easier to work with. In particular, while the general notion directly considers a multi-instance system, the simpler formulation (called EUC) is closer to the original UC notion that considers only a single protocol instance in isolation. We then demonstrate that the two formulations are equivalent. As may be expected, the proof of equivalence incorporates much of the argumentation involved in the proof of the universal composition theorem. We also demonstrate that GUC security is preserved under universal composition.

Related work. Relaxed variants of UC security are studied in [35, 9]. These variants allow reproducing the general feasibility results without setup assumptions other than authenticated communication. However, these results provide significantly weaker security properties than UC-security. In particular, they do not guarantee security in the presence of arbitrary other protocols, which is the focus of this work.

Alternatives to the CRS setup are studied in [5]. As mentioned above, the KRK setup used here is based on the one there, and the protocol for GUC-realizing \mathcal{F}_{com} for non-adaptive corruptions is taken from there. Furthermore, [5] informally discuss the deniability properties of their protocol. However, that work does not address the general concern of guaranteeing security in the presence of global setup. In particular, it adopts the original UC modeling of setup as a construct that is internal to each protocol instance.

In a concurrent work, Hofheinz et. al [28] consider a notion of security that is reminiscent of EUC, with similar motivation to the motivation here. They also formulate a new setup assumption and show how to realize any functionality given that setup. However, their setup assumption is considerably more involved than ours, since it requires the trusted entity to interact with the protocol in an on-line, input-dependent manner. Also, they do not consider adaptive corruptions.

Future work. This work develops the foundations necessary for analyzing security and composability of protocols that use globally available setup. It also re-establishes the feasibility results for general computation in this setting. Still, there are several unexplored research questions here.

One important concern is that of guaranteeing *authenticated communication* in the presence of global PKI setup. As mentioned above, this is another example where the existing notions do not provide the expected security properties (e.g., they do not guarantee deniability, whereas the trusted party solution is expressly deniable). We conjecture that GUC authentication protocols (namely, protocols that GUC-realize ideally authentic communication channels) that use a global PKI setup can be constructed by combining the techniques of [29, 16]. However, we leave full

exploration of this problem out of scope for this work.

The notions of key exchange and secure sessions in the presence of global PKI setup need to be re-visited in a similar way. How can universal composability (and, in particular, deniability) be guaranteed for such protocols? Also, how can existing protocols (that are not deniable) be proven secure with globally available setup?

Organization. Section 2 outlines the two variants of GUC security, states their equivalence, and re-asserts the UC theorem with respect to GUC secure protocols. Section 3 presents the formal impossibility of realizing \mathcal{F}_{com} in the presence of a globally available common reference string, and highlights the need for alternative setup assumptions. Sections 4 and 5 present new globally available setup assumptions, as well as our protocols for realizing any well-formed functionality. Finally, Section 5.2 describes the efficient construction of a useful tool employed in our protocols.

2 Generalized UC Security

Before providing the details for our new security framework, we begin with a high-level overview.

2.1 Overview of Generalized UC Security

We now briefly review the concepts behind the original UC framework of [11] (henceforth referred to as “Basic UC”) before proceeding to outline our new security frameworks. To keep our discussion at a high level of generality, we will focus on the notion of protocol “emulation”, wherein the objective of a protocol π is to emulate another protocol ϕ . Here, typically, π is an implementation (such as the actual “real world” protocol) and ϕ is a specification (such as when the “ideal functionality” \mathcal{F} that we wish to implement is securely computed directly by a trusted entity). Throughout our discussion, all entities and protocols we consider are “efficient” (*i.e.* polynomial time bounded Interactive Turing Machines, in the sense detailed in [12]).

The Basic UC Framework. At a very high level, the intuition behind security in the basic UC framework is that any adversary \mathcal{A} attacking a protocol π should learn no more information than could have been obtained via the use of a simulator \mathcal{S} attacking protocol ϕ . Furthermore, we would like this guarantee to be maintained even if ϕ were to be used as a subroutine of (*i.e.* composed with) arbitrary other protocols that may be running concurrently in the networked environment, and we plan to substitute π for ϕ in all instances. Thus, we may set forth a challenge experiment to distinguish between actual attacks on protocol π , and simulated attacks on protocol ϕ (referring to these protocols as the “challenge protocols”). As part of this challenge scenario, we will allow adversarial attacks to be orchestrated and monitored by a distinguishing environment \mathcal{Z} that is also empowered to control the inputs supplied to the parties running the challenge protocol, as well as to observe the parties’ outputs at all stages of the protocol execution. One may imagine that this environment represents all other activity in the system, including the actions of other protocol sessions that may influence inputs to the challenge protocol (and which may, in turn, be influenced by the behavior of the challenge protocol). Ultimately, at the conclusion of the challenge, the environment \mathcal{Z} will be tasked to distinguish between adversarial attacks perpetrated by \mathcal{A} on the challenge protocol π , and attack simulations conducted by \mathcal{S} with protocol ϕ as the challenge

protocol instead. If no environment can successfully distinguish these two possible scenarios, then protocol π is said to “UC emulate” the protocol ϕ .

Specifying the precise capabilities of the distinguishing environment \mathcal{Z} is crucial to the meaning of this security notion. The environment *must* be able to choose the challenge protocol inputs and observe its outputs, in order to enable the environment to capture the behavior of other activity in the network that interacts with the challenge protocol (which may even be used as a subroutine of another network protocol). Of course, we *must* also grant \mathcal{Z} the ability to interact with the attacker (which will be either the adversary, or a simulation), which models the capability of the attacker to coordinate attacks based on information from other network activity in the environment. As demonstrated in [11], granting precisely these capabilities to \mathcal{Z} (even if we allow it to invoke only a *single session* of the challenge protocol) is sufficient to achieve the strong guarantees of *composition theorem*, which states that any arbitrary instances of the ϕ that may be running in the network can be safely substituted with a protocol π that UC emulates ϕ . Thus, even if we *constrain* the distinguisher \mathcal{Z} to such interactions with the adversary and a *single session* of the challenge protocol (without providing the ability to invoke other protocols at all), we can already achieve the strong security guarantees we intuitively desired. Notably, although the challenge protocol may invoke subroutines of its own, it was not necessary to grant \mathcal{Z} any capability to interact with such subroutines.

In order to conceptually modularize the design of protocols, the notion of “hybrid models” is often introduced into the basic UC framework. A protocol π is said to be realized “in the \mathcal{G} -hybrid model” if π invokes the ideal functionality \mathcal{G} as a subroutine (perhaps multiple times). (As we will soon see below, the notion of hybrid models greatly simplifies the discussion of UC secure protocols that require “setup”.) A high-level conceptual view of UC protocol emulation in a hybrid model is shown in Figure 1.

Limitations of Basic UC. Buried inside the intuition behind the basic UC framework is the critical notion that the environment \mathcal{Z} is capable of utilizing its input/output interface to the challenge protocol to mimic the behavior of other (arbitrary) protocol sessions that may be running in a computer network. Indeed, as per the result of [11] mentioned in our discussion above, this would seem to be the case when considering challenge protocols that are essentially “self-contained”. Such self-contained protocols, which do not make use of any “subroutines” (such as ideal functionalities) belonging to other protocol sessions, are called *subroutine respecting* protocols – and the basic UC framework models these protocols directly. On the other hand, special considerations would arise if the challenge protocol utilizes (or transmits) information that is also shared by other network protocol sessions. An example of such information would be the use of a global setup, such as a public “common reference string” (CRS) that is reused from one protocol session to the next, or a standard Public Key Infrastructure (PKI). Such shared state is not directly modeled by the basic UC framework discussed above. In fact, the composition theorem of [11] only holds when considering instances of subroutine respecting protocols (which *do not* share any state information with other protocol sessions). Unfortunately, it is impossible to produce UC secure realizations of most useful functionalities without resorting to some setup. However, to comply with the requirements of the UC framework, the setup would have to be done on a per-instance basis. This does not faithfully represent the common realization, where the same setup is shared by all instances. Therefore, previous works handled such “shared state” protocol design situations via a special proof

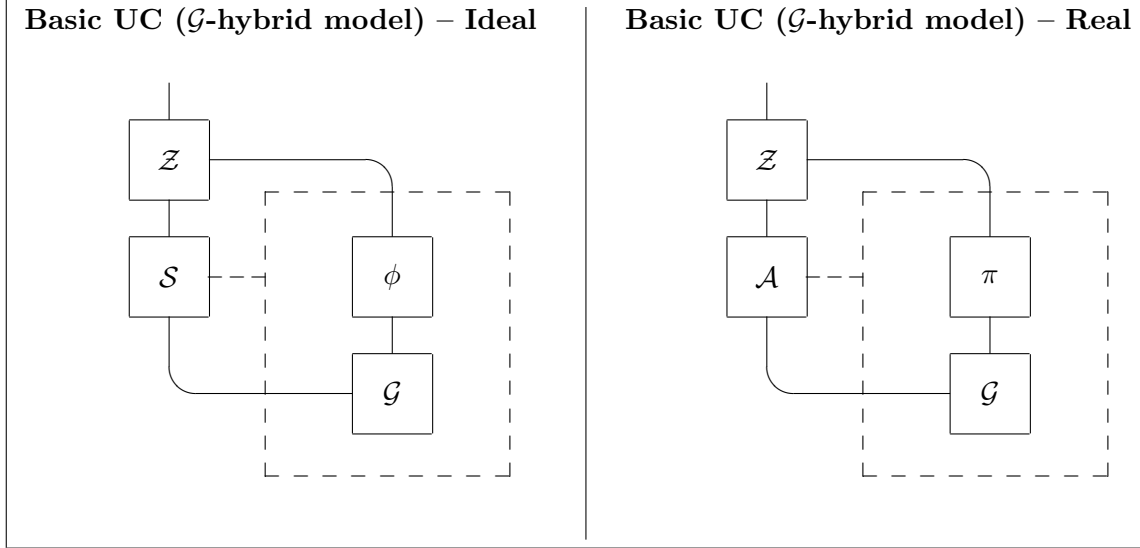

Figure 1: The Basic UC Experiment in the \mathcal{G} -hybrid model. A simulator \mathcal{S} attacks a single session of protocol ϕ running with an ideal subroutine \mathcal{G} , whereas an arbitrary “real” adversary \mathcal{A} attacks a session of π running with an ideal subroutine \mathcal{G} . The dashed box encloses protocols where \mathcal{S} or \mathcal{A} control the network communications, whereas the solid lines represent a direct Input/Output relationship. (In a typical scenario, ϕ would be the ideal protocol for a desired functionality \mathcal{F} , whereas π would be a practical protocol realizing \mathcal{F} , with \mathcal{G} modeling some “setup” functionality required by π . Observe that the environment can never interact directly with \mathcal{G} , and thus, in this particular scenario, \mathcal{G} is never invoked at all in the ideal world since we are typically interested in the case where ideal protocol for \mathcal{F} does not make use of \mathcal{G} .)

technique, known as the JUC Theorem [19].

Yet, even the JUC Theorem does not accurately model truly *global* shared state information. JUC Theorem only allows for the construction of protocols that share state *amongst themselves*. That is, an *a-priori* fixed set of protocols can be proven secure if they share state information *only* with each other. No security guarantee is provided in the event that the shared state information is also used by other protocols which the original protocols were not specifically designed to interact with. Of course, malicious entities may take advantage of this by introducing new protocols that use the shared state information if the shared state is publicly available. In particular, protocols sharing global state (*i.e.* using global setups) which are modeled in this fashion may not resist adaptive chosen protocol attacks, and can suffer from a lack of deniability, as we previously mentioned regarding the protocols of [16], [18], and as is discussed in further detail in Section 3.2.

The Generalized UC Framework. To summarize the preceding discussion, the environment \mathcal{Z} in the basic UC experiment is unable to invoke protocols that share state in any way with the challenge protocol. This limitation is unrealistic in the case of global setup, when protocols share state information with each other (and indeed, it was shown to be impossible to realize UC-secure protocols without resort to such tactics [16, 11, 17]). To overcome this limitation, we propose the

Generalized UC (GUC) framework. The GUC challenge experiment is similar to the basic UC experiment, only with an *unconstrained* environment. In particular, we will allow \mathcal{Z} to actually invoke and interact with arbitrary protocols, and even multiple sessions of its challenge protocol (which may be useful to \mathcal{Z} in its efforts to distinguish between the two possible challenge protocols). Some of the protocol sessions invoked by \mathcal{Z} may share state information with challenge protocol sessions, and indeed, they can provide \mathcal{Z} with information about the challenge protocol that it could not have obtained otherwise. The only remaining limitation on \mathcal{Z} is that we prevent it from directly observing or influencing the network communications of the challenge protocol sessions, but this is naturally the job of the adversary (which \mathcal{Z} directs). Thus, the GUC experiment allows a very powerful distinguishing environment capable of truly capturing the behavior of arbitrary protocol interactions in the network, *even if protocols can share state information with arbitrary other protocols*. Of course, protocols that are GUC secure are also composable (this fact follows almost trivially from a greatly simplified version of the composition theorem proof of [12], the simplifications being due to the ability of the unconstrained environment to directly invoke other protocol sessions rather than needing to “simulate” them internally).

The Externalized UC Framework. Unfortunately, since the setting of GUC is so complex, it becomes extremely difficult to prove security of protocols in our new GUC framework. Essentially, the distinguishing environment \mathcal{Z} is granted a great deal of freedom in its choice of attacks, and any proof of protocol emulation in the GUC framework must hold even in the presence of other arbitrary protocols running concurrently. To simplify matters, we observe that in practice protocols which are designed to share state do so only in a very limited fashion (such as via a single common reference string, or a PKI, etc.). In particular, we will model shared state information via the use of “shared functionalities”, which are simply functionalities that may interact with more than one protocol session (such as the CRS functionality). For clarity, we will distinguish the notation for shared functionalities by adding a bar (*i.e.* we use $\bar{\mathcal{G}}$ to denote a shared functionality). We call a protocol π that *only* shares state information via a single shared functionality $\bar{\mathcal{G}}$ a $\bar{\mathcal{G}}$ -subroutine respecting protocol. Bearing in mind that it is generally possible to model “reasonable” protocols that share state information as $\bar{\mathcal{G}}$ -subroutine respecting protocols, we can make the task of proving GUC security simpler by considering a compromise between the constrained environment of basic UC and the unconstrained environment of GUC. An $\bar{\mathcal{G}}$ -externally constrained environment is subject to the same constraints as the environment in the basic UC framework, only it is additionally allowed to invoke a single “external” protocol (specifically, the protocol for the shared functionality $\bar{\mathcal{G}}$). Any state information that will be shared by the challenge protocol must be shared via calls to $\bar{\mathcal{G}}$ (*i.e.* challenge protocols are $\bar{\mathcal{G}}$ -subroutine respecting), and the environment is specifically allowed to access $\bar{\mathcal{G}}$. Although \mathcal{Z} is once again constrained to invoking a single instance of the challenge protocol, it is now possible for \mathcal{Z} to internally mimic the behavior of multiple sessions of the challenge protocol, or other arbitrary network protocols, by making use of calls to $\bar{\mathcal{G}}$ wherever shared state information is required. Thus, we may avoid the need for JUC Theorem (and the implementation limitations it imposes), by allowing the environment direct access to shared state information (*e.g.* we would allow it to observe the Common Reference String when the shared functionality is the CRS functionality). We call this new security notion Externalized UC (EUC) security, and we say that a $\bar{\mathcal{G}}$ -subroutine respecting protocol π $\bar{\mathcal{G}}$ -EUC-emulates a protocol ϕ if π emulates ϕ in the basic UC sense with respect to $\bar{\mathcal{G}}$ -externally constrained environments.

We show that if a protocol π $\bar{\mathcal{G}}$ -EUC-emulates ϕ , then it also GUC emulates ϕ (and vice versa, provided that π is $\bar{\mathcal{G}}$ -subroutine respecting).

Theorem 2.1. *Let π be any protocol which invokes no shared functionalities other than (possibly) $\bar{\mathcal{G}}$, and is otherwise subroutine respecting (i.e. π is $\bar{\mathcal{G}}$ -subroutine respecting). Then protocol π GUC-emulates a protocol ϕ , if and only if protocol π $\bar{\mathcal{G}}$ -EUC-emulates ϕ .*

That is, provided that π only shares state information via a single shared functionality $\bar{\mathcal{G}}$, if it merely EUC-emulates ϕ with respect to that functionality, then π is a full GUC-emulation of ϕ ! As a special case, we obtain that all basic UC emulations (which may not share *any* state information) are also GUC emulations.

Corollary 2.2. *Let π be any subroutine respecting protocol. Then protocol π GUC-emulates a protocol ϕ , if and only if π UC-emulates ϕ .*

The corollary follows by letting $\bar{\mathcal{G}}$ be the null functionality, and observing that the $\bar{\mathcal{G}}$ -externally constrained environment of the EUC experiment collapses to become the same environment as that of the basic UC experiment when $\bar{\mathcal{G}}$ is the null functionality. Thus, it is sufficient to prove basic UC security for protocols with no shared state, or $\bar{\mathcal{G}}$ -EUC security for protocols that share state only via $\bar{\mathcal{G}}$, and we will automatically obtain the full benefits of GUC security. The proof of the theorem is given in Section 2.2.

Figure 2 depicts the differences in the experiments of the UC models we have just described, in the presence of a single shared functionality $\bar{\mathcal{G}}$ (of course, the GUC framework is not inherently limited to special case of only one shared functionality). In Section 2.2 we elaborate the technical details of our new models, in addition to proving the equivalence of GUC and EUC security.

We are now in a position to state a strong new composition theorem, which will directly incorporate the previous result (that proving EUC security is sufficient for GUC security). Let ρ be an arbitrary protocol (not necessarily subroutine respecting!) which invokes ϕ as a sub-protocol. We will write $\rho^{\pi/\phi}$ to denote a modified version of ρ that invokes π instead of ϕ , wherever ρ had previously invoked ϕ . We prove the following general theorem in Section 2.2 below:

Theorem 2.3 (Generalized Universal Composition). *Let ρ, π, ϕ be PPT multi-party protocols, and such that both ϕ and π are $\bar{\mathcal{G}}$ -subroutine respecting, and π $\bar{\mathcal{G}}$ -EUC-emulates ϕ . Then $\rho^{\pi/\phi}$ GUC-emulates protocol ρ .*

We stress that π must merely $\bar{\mathcal{G}}$ -EUC-emulate ϕ , but that the resulting composed protocol $\rho^{\pi/\phi}$ fully GUC-emulates ρ , even for a protocol ρ that is not subroutine respecting.

2.2 Details of the Generalized UC Framework

We now present more formal details of our new generalized UC (GUC) framework, and discuss its relationship to basic UC Security. (Here we will refer to the formulation of UC security in [12]). We also present a simplified variant of the new notion called Externalized UC (EUC), and prove its equivalence. Finally, we re-assert the universal composition theorem with respect to the new notion. Many of the low-level technical details, especially those that are essentially identical to those of the basic UC framework, are omitted. A full treatment of these details can be found in [12]. In particular, we do not discuss the proper modeling of polynomial runtime restrictions, the

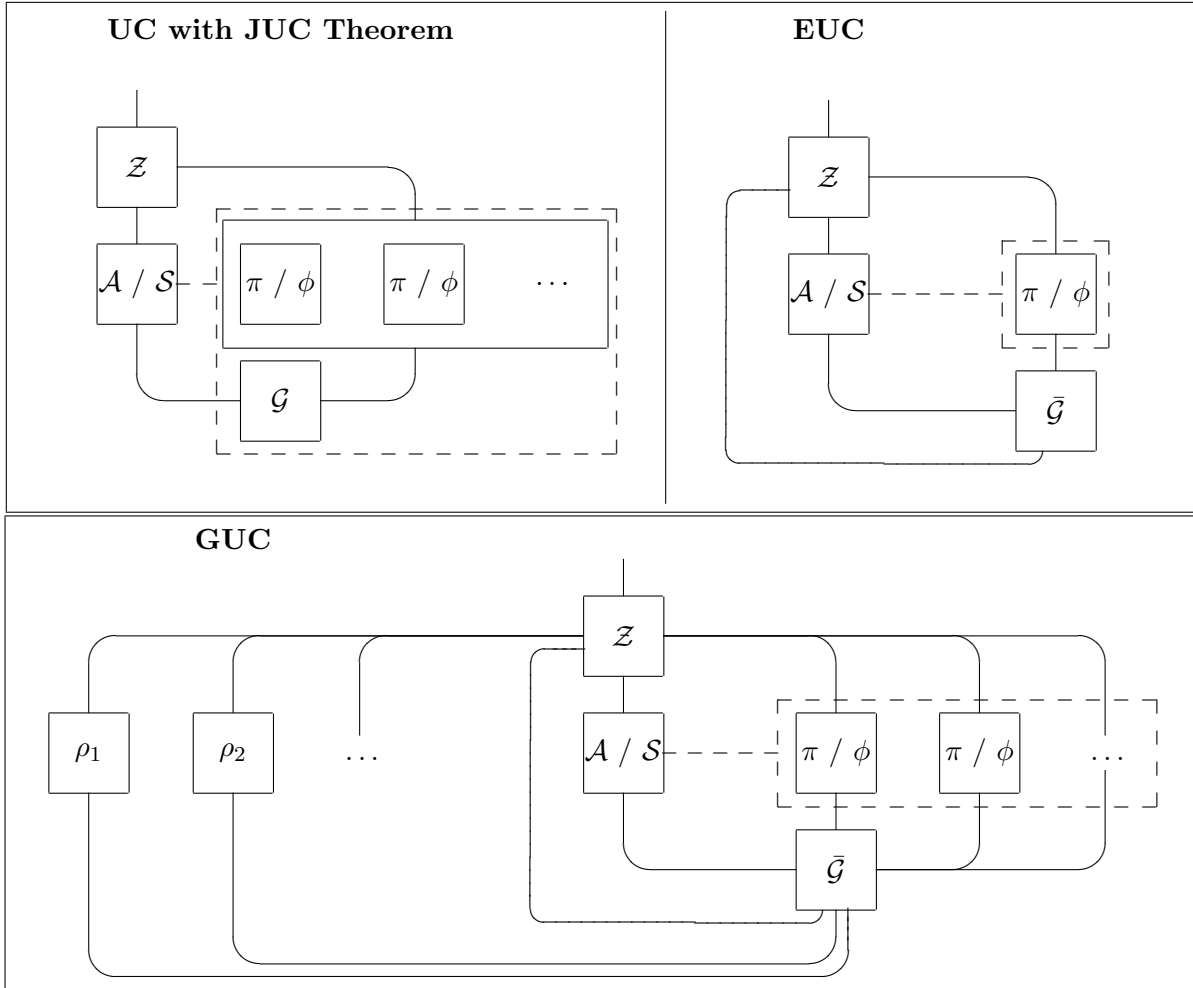

Figure 2: Comparison of models. Using Basic UC with JUC Theorem to share state, only copies of the challenge protocol (or other protocols which may be jointly designed a priori to share \mathcal{G}) are allowed to access the common subroutine \mathcal{G} , and \mathcal{Z} may only interact with the “multi-session” version of the challenge protocol. In the EUC paradigm, only a single session of the challenge protocol is running, but the shared functionality $\bar{\mathcal{G}}$ it uses is accessible by \mathcal{Z} . Finally, in the GUC setting, we see the full generality of arbitrary protocols ρ_1, ρ_2, \dots running in the network, alongside multiple copies of the challenge protocol. Observe that both \mathcal{Z} , and any other protocols invoked by \mathcal{Z} (such as ρ_1), have direct access to $\bar{\mathcal{G}}$ in the GUC setting. Intuitively, the GUC modeling seems much closer to the actual structure of networked protocol environments.

order of activations, etc. These issues are handled as in the basic UC framework, which we now briefly review.

2.2.1 Basic UC Security

The basic UC framework is built around the notion of *UC emulation*. A protocol is a UC secure *realization* of an *ideal functionality* (which models the security goal), if it UC-emulates the ideal functionality, in the sense that executing the protocol is indistinguishable for an external environment from an interaction with a trusted party running the ideal functionality. Before reviewing the actual “UC experiment” that defines the notion of UC emulation, we first briefly review the basic model of distributed computation, using interactive Turing machines (ITMs). While we do not modify this model, familiarity with it is important for understanding our generalization.

Systems of ITMs. To capture the mechanics of computation and communication in computer networks, the UC framework employs an extension of the Interactive Turing Machine (ITM) model [25] (see [12] for precise details on the additional extensions). A computer program (such as for a protocol, or perhaps program of the adversary) is modeled in the form of an ITM (which is an abstract notion). An execution experiment consists of a *system* of ITMs which are instantiated and executed, with multiple instances possibly sharing the same ITM code. (More formally, a system of ITMs is governed by a *control function* which enforces the rules of interaction among ITMs as required by the protocol execution experiment. Here we will omit the full formalisms of the control function, which can be found in [12], and which require only minor modifications for our setting.)

A particular executing ITM instance running in the network is referred to as an ITI (or “ITM Instance”), and we must have a means to distinguish individual ITIs from one another even if they happen to be running identical ITM code. Therefore, in addition to the program code of the ITM they instantiate, individual ITIs are parameterized by a *party ID* (*pid*) and a *session ID* (*sid*). We require that each ITI can be uniquely identified by the *identity* pair $\text{id} = (\text{pid}, \text{sid})$, irrespective of the code it may be running. All ITIs running with the same code and session ID are said to be a part of the same *protocol session*, and the party IDs are used to distinguish among the various ITIs participating in a particular protocol session. (By the uniqueness of ITI identities, no party is allowed to participate in more than one protocol session using the same session ID.) For simplicity of exposition, we assume that all *sids* are unique, i.e. no two sessions have the same *SID*. (The treatment can be generalized to the case where the same *SID* is used by different protocol codes, at the price of somewhat more complicated formalism.) We also refer to a protocol session running with ITM code π as an *instance* of protocol π . ITMs are allowed to communicate with each other via the use of three kinds of I/O tapes: local *input tapes*, local *subroutine output* tapes, and *communication tapes*. The input and subroutine output tapes model “trusted communication”, say communication within a single physical computer. The communication tape models “untrusted communication”, say communication over an open network. Consequently, writes to the local input tapes of a particular ITI must include both the *identity and the code* of the intended target ITI, and the ITI running with the specified identity must also be running the specified code, or else an error condition occurs. Thus, input tapes may be used to invoke local “trusted” subroutines, and indeed, new ITIs must be introduced into the currently executing system by means of such invocations. That is, if a target ITI with the specified identity does not exist, it is created (“invoked”), and given the specified code. We also require that when an ITI writes to the local subroutine output

tape of another ITI, it must provide its own code, and thus these tapes are useful for accepting output from such local “trusted” subroutines. Finally, all “untrusted” communications are passed via the communication tapes, which guarantee neither the code of the intended recipient ITI, nor the code of the sending ITI (but merely their identities).

The UC Protocol Execution Experiment. The UC protocol execution experiment is defined as a system of ITMs that’s parameterized by three ITMs. An ITM π specifies the code of the *challenge protocol* for the experiment, an ITM \mathcal{A} specifies the code of the *adversary*, and an ITM \mathcal{Z} provides the code of the *environment*. The protocol execution experiment places precise conditions on the order in which ITIs are activated, and which ITIs are allowed to invoke or communicate with each other. The precise formal details of how these conditions are defined and imposed (*i.e.* the control function and related formalisms) can be found in [12], but we shall describe some of the relevant details informally. The experiment initially launches only an ITI running \mathcal{Z} . In turn, \mathcal{Z} is permitted to invoke only a single ITI running \mathcal{A} , followed by (multiple) ITIs running the “challenge protocol” π *provided that those ITIs running π all share the same sid*. This sid, along with the pids of all the ITIs running π , may be chosen arbitrarily by \mathcal{Z} .

It is stressed that the environment *may not* invoke any additional ITIs, and it is only allowed to write to the input tapes of ITIs which it has directly invoked (or to receive outputs from those ITIs via its subroutine output tape). The environment may not interact with *any* of the communication tapes, nor the tapes of ITIs that it did not directly invoke. In summary, the environment can communicate only with the ITI running the code of the adversary \mathcal{A} , and ITIs participating in a single session of protocol π . We thus refer to the execution experiment as being a *constrained* one, and, in particular, the environment \mathcal{Z} as being a *constrained environment*. The output of the environment \mathcal{Z} in this basic UC protocol execution experiment is denoted by $\text{EXEC}_{\pi, \mathcal{A}, \mathcal{Z}}$.

Ideal Functionalities. We say an ITM \mathcal{F} is an *ideal functionality* if its code represents a desired (interactive) function to be computed by parties or other protocols which may invoke it *as a subroutine* (and thus, in a perfectly secure way). The pid of any ITI running \mathcal{F} is set to the special value \perp , indicating that the ITI is an ideal functionality. \mathcal{F} accepts input from other ITIs that have the same sid as \mathcal{F} , and may write outputs to multiple ITIs as well.

Every ideal functionality \mathcal{F} also induces an *ideal protocol* $\text{IDEAL}_{\mathcal{F}}$. Parties running $\text{IDEAL}_{\mathcal{F}}$ with the session ID sid act as *dummy parties*, simply forwarding their inputs to the input tape of an ITI running \mathcal{F} with the same sid, and copying any subroutine output received from \mathcal{F} to the subroutine output tape of the ITI which invoked the party (typically, the environment \mathcal{Z}).

UC Emulation and Realizations. In the basic UC framework, a protocol π is said to *UC-emulate* another protocol ϕ if, for any adversary \mathcal{A} , there exists a *simulator* \mathcal{S} such that for all environments \mathcal{Z} it holds that $\text{EXEC}_{\phi, \mathcal{S}, \mathcal{Z}} \approx \text{EXEC}_{\pi, \mathcal{A}, \mathcal{Z}}$. That is, no environment behaves significantly differently in the protocol execution experiment when interacting with the challenge protocol π , under any given attack, than it does when interacting with the challenge protocol ϕ , under a simulation of that same attack. Intuitively, this means that the protocol π is “at least as secure as” the protocol ϕ , since the effect of any attack on π can also be emulated by attacking ϕ . A protocol π is said to *UC-realize* an ideal functionality \mathcal{F} if π UC-emulates $\text{IDEAL}_{\mathcal{F}}$. Furthermore, if the

protocol π is a \mathcal{G} -hybrid protocol, then we say that π is a UC-secure realization of \mathcal{F} in the \mathcal{G} -hybrid model.

2.2.2 Generalized UC Security

We present the generalized variant of UC security. Technically, the difference is very small; however, its effect is substantial. The essential difference here from the basic UC security notion is that here the environment \mathcal{Z} is allowed to invoke ITIs with arbitrary code and arbitrary SIDs, including multiple concurrent instances of the challenge protocol π and other protocols. We stress that these ITIs are even allowed to *share state* with each other across multiple sessions (which is a significant departure from prior models). To simplify the presentation and analysis, we will still assume that \mathcal{Z} invokes only a single instance of the adversary \mathcal{A} .¹ We call such an environment *unconstrained*, since it need not obey any constraints in regards to which protocols it may invoke.² To distinguish from the basic UC experiment, we denote the output of an unconstrained environment \mathcal{Z} attempting to distinguish a challenge protocol π in the GUC protocol execution experiment, with an adversary \mathcal{A} , as $\text{GEXEC}_{\pi, \mathcal{A}, \mathcal{Z}}$. GUC emulation, is now defined as follows, analogously to the definition of basic UC emulation outlined above:

Definition 1 (GUC-Emulation). *Let π and ϕ be PPT multi-party protocols. We say that π GUC-emulates ϕ if, for any PPT adversary \mathcal{A} there exists a PPT adversary \mathcal{S} such that for any (unconstrained) PPT environment \mathcal{Z} , we have:*

$$\text{GEXEC}_{\phi, \mathcal{S}, \mathcal{Z}} \approx \text{GEXEC}_{\pi, \mathcal{A}, \mathcal{Z}}$$

As long as the protocol in question makes sure that no instance shares any subroutines with other protocol instances, GUC security is equivalent to basic UC security. This statement, which intuitively follows from the universal composition theorem, will be formalized later. However, we are primarily interested in protocols that *do* share some modules, or subroutines, with other protocol instances. For such protocols the generalized formulation differs radically from the basic one. Specifically, we are interested in modeling “shared trusted modules”, which are captured via the **shared ideal functionality** construct.

Shared Ideal Functionalities. In addition to the notion of ideal functionalities inherited from the basic UC security setting, we coin the notion of *shared functionalities*. A shared functionality $\bar{\mathcal{G}}$ is completely analogous to an ideal functionality, only it may additionally accept inputs from ITIs with *arbitrary* session IDs. Thus, a shared functionality is just an ideal functionality that may communicate with more than one protocol session. In order to distinguish shared functionalities from ideal functionalities, we require the `sid` of a shared functionality to begin with the special

¹Although it is conceptually interesting to consider scenarios where the environment may invoke separate adversaries to attack separate instances of the challenge protocol, particularly when there is some shared state, it can be shown that this notion is equivalent to our simplified single adversary model.

²More formally, the control function for the GUC protocol execution experiment allows \mathcal{Z} to invoke ITIs running arbitrary ITM code, and with arbitrary (but unique) identities. In particular, the environment may invoke many ITIs with a special code \perp (even with different `sids`), which the control function will substitute for ITIs running π . Thus, the reason for our departure with the convention of [12] (which replaces the code of all ITIs invoked by \mathcal{Z} with instances of π) is to provide \mathcal{Z} with the ability to invoke ITIs running arbitrary code (other than π), yet still enable it to invoke instances of the challenge protocol without having access to its code.

symbol $\#$ (which is used exclusively in the sid of shared functionalities). As a shorthand notation, we denote the portion of the sid of a shared functionality which follows the $\#$ symbol by shsid (and thus, shared functionalities have $\text{sid} = \#||\text{shsid}$). Similarly to ideal functionalities, shared functionalities also have $\#$ as their fixed pid , and thus all shared functionalities have fixed identities (and can be invoked only by specifying the code of their corresponding ITM).

Discussion. Recall that in the basic UC definition, \mathcal{Z} is constrained in its ability to invoke protocols: it may only invoke precisely those parties participating in the one single session of the challenge protocol it is attempting to distinguish, and aside from its ability to invoke and communicate with an adversary it may not invoke any other ITIs (*e.g.* representing other parties and protocol sessions concurrently running in the network) of any sort. Intuitively, it would seem that if this constraint were removed and \mathcal{Z} were allowed to invoke arbitrary ITIs running arbitrary protocols (including multiple concurrent sessions of the challenge protocol itself), that \mathcal{Z} would become a more powerful distinguisher (strengthening the security requirements for protocols to remain indistinguishable). As we will see, in reality, since basic UC security does not allow protocols to *share state*³ with each other, any concurrent protocol executions that \mathcal{Z} might wish to run can simply be simulated by \mathcal{Z} internally with no need to actually invoke the ITIs. Thus, the constraint that \mathcal{Z} may only invoke parties running a single instance of the protocol it is attempting to distinguish is not a true limitation, and indeed this is where the power of UC security comes from (*e.g.* the ability for \mathcal{Z} to conduct this kind of internal simulation is why UC security holds even in the presence of concurrent protocol executions).

Unlike this basic UC security setting, we wish to consider definitions of security even for protocols that may share state information externally with other (concurrently executing) sessions of the same protocol, or even with other (independently designed) protocols. In such a setting, it is no longer possible for \mathcal{Z} to simulate other protocol executions internally, since some of those protocols may share state with the protocol that \mathcal{Z} is attempting to distinguish. Thus, the constraints placed on \mathcal{Z} in the basic UC setting are of great concern for us, since they would prevent \mathcal{Z} from ever seeing the effects of other protocol executions that share state externally with the protocol \mathcal{Z} is attempting to distinguish, whereas protocol executions in the real world would certainly involve such effects. In order to properly capture interactions between protocols which share state information externally, we introduce the notion of Generalized UC (GUC) security, which builds off the basic UC security concepts outlined above.

Here we note that the differences between GUC-emulation and basic UC-emulation are in the use of an unconstrained environment, and the ability of π and ϕ to invoke shared functionalities (which is not allowed in the basic UC setting). As an important intuition, we observe that since \mathcal{Z} may invoke ITIs with arbitrary code, it may invoke ITIs which communicate with any shared functionalities invoked by π (or ϕ). Thus, \mathcal{Z} may essentially access shared functionalities in an arbitrary manner (the primary restriction being the uniqueness of the identities of the ITIs which \mathcal{Z} may invoke).

Intuitively, we call this security notion Generalized UC since the challenge protocol may interact with *external* protocols in an arbitrary manner. Whereas in the basic UC security setting, external

³The typical example of protocols sharing state occurs when using the CRS model. Multiple instances of a protocol may all share the same CRS, which certainly implies a relationship between those protocol executions which is not captured by standard UC security.

protocols were viewed as being independent of the challenge protocol itself, in the GUC setting shared functionalities may link the “state” of the challenge protocol to the state of other protocols running in the network which may seem completely external to the challenge protocol session under consideration.

2.2.3 Externalized UC Security

Since the unconstrained environment in GUC security setting we have just described is able to invoke arbitrary ITIs (and thus cause arbitrary interactions with shared functionalities, etc.), it becomes difficult to directly prove that a protocol GUC-emulates another protocol, *i.e.* to show that a simulated adversary \mathcal{S} attacking a protocol ϕ behaves indistinguishably from an actual adversary \mathcal{A} attacking protocol π . In particular, such analysis seems to directly involve arguing about systems where multiple instances of multiple protocols run concurrently. This stands in contrast to the situation with basic UC security, where it suffices to analyze a single instance of the protocol in isolation, and security in a multi-instance system follows from a general composition theorem.

We alleviate this situation in two steps: As a first step, we formulate another notion of protocol emulation, called **externalized UC emulation**, which is considerably simpler and in particular considers only a single instance of the protocol in question. We then show that this simplified notion is equivalent to the above general notion. In a second step, we re-assert the universal composition theorem with respect to GUC-emulation.

We remark that in the basic UC framework these two conceptual steps are demonstrated via the same technical theorem (namely, the UC theorem). We find that in the present framework it is clearer to separate the two issues.

Subroutine respecting protocols. Before proceeding to define externalized UC emulation, we coin the following terminology. We say that an ITI M is a *subroutine* of another ITI M' if M either receives inputs on its input tape from M' (and does not explicitly ignore them), or writes outputs to the subroutine output tape of M' . Recursively, we also say that if M is a subroutine of a party (ITI) running protocol π or a *sub-party* of protocol π , then M is a *sub-party* of protocol π . By uniqueness of session identifiers, if there is an instance of protocol π running with session ID sid , all ITIs running with session ID sid are running π or are sub-parties of π .

A protocol π is said to be $\bar{\mathcal{G}}$ -*subroutine respecting* if none of the sub-parties of an instance of π provides output to or receives input from any ITI that is not also party/sub-party of that instance of π , *except* for communicating with a *single instance* of the shared ITI $\bar{\mathcal{G}}$. In other words, an instance of a $\bar{\mathcal{G}}$ -subroutine respecting protocol π has the property that all sub-parties of this instance of π are only allowed to communicate with parties or sub-parties of this same instance of π (they do not share themselves with other protocol instances in any way), with the sole exception that calls to a shared functionality $\bar{\mathcal{G}}$ are allowed. Using this terminology, we can now define externalized UC emulation.

The Externalized UC Protocol Execution Experiment. Rather than allowing the environment to operate completely unconstrained as in the GUC experiment, we constrain the environment so that it may only invoke particular types of ITIs. Specifically, the environment is only allowed

to invoke a single instance of the challenge protocol (as in the constrained environment of basic UC), plus a *single* ITI running the code of a shared ideal functionality (i.e., a shared subroutine) $\bar{\mathcal{G}}$. In other words, the EUC experiment is the same as the basic UC experiment, except the (otherwise constrained) environment is also allowed to provide input to and obtain output from a single instance of a shared ideal functionality (which is specified by the challenge protocol under consideration). We say that such an environment is $\bar{\mathcal{G}}$ -externally constrained if it is allowed such extra access to a shared functionality $\bar{\mathcal{G}}$. (Note that although we consider only one shared functionality at a time for the sake of simplicity, it is also reasonable to define the notions of “subroutine respecting” and “EUC security” with respect to multiple shared functionalities.) Given a $\bar{\mathcal{G}}$ -subroutine respecting protocol π , we denote the output of the environment in the $\bar{\mathcal{G}}$ -EUC protocol experiment by $\text{EXEC}_{\pi, \mathcal{A}, \mathcal{Z}}^{\bar{\mathcal{G}}}$. EUC-emulation is defined analogously to the notion of GUC-emulation:

Definition 2 (EUC-Emulation). *Let π and ϕ be PPT multi-party protocols, where π is $\bar{\mathcal{G}}$ -subroutine respecting. We say that π EUC-emulates ϕ with respect to shared functionality $\bar{\mathcal{G}}$ (or, in shorthand, that π $\bar{\mathcal{G}}$ -EUC-emulates ϕ) if for any PPT adversary \mathcal{A} there exists a PPT adversary \mathcal{S} such that for any $\bar{\mathcal{G}}$ -externally constrained environment \mathcal{Z} , we have:*

$$\text{EXEC}_{\phi, \mathcal{S}, \mathcal{Z}}^{\bar{\mathcal{G}}} \approx \text{EXEC}_{\pi, \mathcal{A}, \mathcal{Z}}^{\bar{\mathcal{G}}}$$

$\bar{\mathcal{G}}$ -EUC Secure Realization. We say that a protocol π *realizes* an ideal functionality \mathcal{F} if π $\bar{\mathcal{G}}$ -EUC-emulates $\text{IDEAL}_{\mathcal{F}}$. Notice that the formalism implies that the shared functionality $\bar{\mathcal{G}}$ exists both in the model for executing π and also in the model for executing the ideal protocol for \mathcal{F} , $\text{IDEAL}_{\mathcal{F}}$.

We remark that the notion of $\bar{\mathcal{G}}$ -EUC-emulation can be naturally extended to protocols that use several different shared functionalities (instead of only one).

2.2.4 Equivalence of GUC to EUC and a generalized UC theorem

We show that $\bar{\mathcal{G}}$ -EUC-emulation is, surprisingly, equivalent to full GUC-emulation for any $\bar{\mathcal{G}}$ -subroutine respecting protocol. Perhaps unsurprisingly, the proof of the equivalence theorem incorporates most of the arguments of the universal composition theorem. In particular, the “quality” of security degrades linearly with the number of instances of π invoked by \mathcal{Z} in the GUC experiment.

The formal statement of this equivalence is given in Theorem 2.1 above. The proof of the theorem, which we now give, makes use of a hybrid argument (akin to that in the universal composition theorem of [12]) to show that security for the single-instance setting of EUC is sufficient to ensure security under the more strenuous multi-instance setting of GUC.

Proof of Theorem 2.1. It is trivial to observe that protocols which GUC-emulate each other also $\bar{\mathcal{G}}$ -EUC-emulate each other (since any simulation that is indistinguishable to unconstrained environments is certainly indistinguishable to the special case of $\bar{\mathcal{G}}$ -externally constrained environments as well), but the other direction is non-obvious. The basic idea of the proof is that an $\bar{\mathcal{G}}$ -externally constrained environment can simulate the same information available to an unconstrained environment, even while operating within its constraints. The proof technique is essentially the same as the proof of composition theorem, only in this case multiple sessions must be handled directly without going through an intermediate protocol. (That is, the proof of composition theorem considers a

protocol π which emulates a protocol ϕ , and shows that a protocol ρ which may invoke multiple copies of π emulates a protocol ρ which invokes ϕ instead. Here, we essentially need to demonstrate that if a single copy of π emulates ϕ then multiple copies of π emulate multiple copies of ϕ .)

Applying the technique of [12], we observe that there are equivalent formulations of protocol emulation with respect to dummy adversaries (this needs to be proven separately, but the proofs are identical to those for the original notion of UC emulation), and we will use those formulations here to simplify the proof. Let \mathcal{D} denote the fixed “dummy adversary” (which simply forwards messages to and from the environment). For the remainder of the proof, we shall refer to the “simulator \mathcal{S} ” as the “adversary”, in order to avoid confusion (roughly speaking, \mathcal{S} attempts to simulate the attack of an adversary, so this terminology is appropriate).

Suppose that π $\bar{\mathcal{G}}$ -EUC-emulates ϕ . This means there exists some adversary \mathcal{S} that will satisfy $\text{EXEC}_{\pi, \mathcal{D}, \mathcal{Z}}^{\bar{\mathcal{G}}} \approx \text{EXEC}_{\phi, \mathcal{S}, \mathcal{Z}}^{\bar{\mathcal{G}}}$ for any $\bar{\mathcal{G}}$ -externally constrained environment \mathcal{Z} . To prove our claim, we will need to show that the existence of such \mathcal{S} is sufficient to construct a new adversary $\tilde{\mathcal{S}}$ such that $\text{GEXEC}_{\pi, \mathcal{D}, \tilde{\mathcal{Z}}} \approx \text{GEXEC}_{\phi, \tilde{\mathcal{S}}, \tilde{\mathcal{Z}}}$ holds for any unconstrained environment $\tilde{\mathcal{Z}}$.

We construct an adversary $\tilde{\mathcal{S}}$ in a similar fashion to the construction of \mathcal{A}_π in the proof of composition theorem in [12], using multiple instances of \mathcal{S} that are simulated by \mathcal{A}_π internally. That is, to ensure that each instance of ϕ mimics the corresponding instance of π , $\tilde{\mathcal{S}}$ will run separate copies of \mathcal{S} for each instance of π (and $\tilde{\mathcal{S}}$ then simply forwards messages between $\tilde{\mathcal{Z}}$ and the corresponding copy of \mathcal{S} for that instance when necessary). We now prove that $\tilde{\mathcal{S}}$ satisfies the requirement for GUC-emulation via a hybrid argument (again, as is done in the proof of composition theorem).

Assume for the purpose of contradiction that $\text{EXEC}_{\pi, \mathcal{D}, \tilde{\mathcal{Z}}}^{\bar{\mathcal{G}}} \not\approx \text{EXEC}_{\phi, \tilde{\mathcal{S}}, \tilde{\mathcal{Z}}}^{\bar{\mathcal{G}}}$ (in particular, assume the distinguishing advantage of $\tilde{\mathcal{Z}}$ is ϵ). Let m be an upper bound on the number of instances of π which are invoked by $\tilde{\mathcal{Z}}$. For $l \leq m$, let $\tilde{\mathcal{S}}_l$ denote the adversary for a modified execution $\text{EX}_l = \text{EXEC}(l, \phi)_{\pi, \tilde{\mathcal{S}}_l, \tilde{\mathcal{Z}}}^{\bar{\mathcal{G}}}$ in which the first l instances of π are simulated⁴ using instances of \mathcal{S} and ϕ (as would be done by $\tilde{\mathcal{S}}$), but the remaining invocations of π by $\tilde{\mathcal{Z}}$ are in fact handled by genuine instances of π (with $\tilde{\mathcal{S}}_l$ simply forwarding messages directly to and from those instances, as \mathcal{D} would). In particular, we observe that the modified interaction EX_0 is just the interaction with π , and EX_l is the unmodified interaction with $\tilde{\mathcal{S}}$ and ϕ replacing \mathcal{D} and π . Then, by our assumption that the interactions with EX_0 and EX_m are distinguishable, there must be an $0 < l \leq m$ such that $\tilde{\mathcal{Z}}$ distinguishes between the modified interactions with EX_l and EX_{l-1} with advantage at least ϵ/m . We can construct an $\bar{\mathcal{G}}$ -externally constrained environment \mathcal{Z}^* from such a $\tilde{\mathcal{Z}}$ which succeeds in distinguishing the ensembles $\text{EXEC}_{\pi, \mathcal{D}, \mathcal{Z}^*}^{\bar{\mathcal{G}}}$ and $\text{EXEC}_{\phi, \mathcal{S}, \mathcal{Z}^*}^{\bar{\mathcal{G}}}$ with probability at least ϵ/m , contradicting the fact that π $\bar{\mathcal{G}}$ -EUC-emulates ϕ .

The construction of \mathcal{Z}^* is slightly involved, but on a high level, \mathcal{Z}^* internally simulates the actions of $\tilde{\mathcal{Z}}$ including all ITIs activated by $\tilde{\mathcal{Z}}$ (other than those for $\bar{\mathcal{G}}$ and the l -th instance of π), but forwards all communications sent to the l -th instance of π to its own external interaction instead (which is either with a single instance of π and \mathcal{D} , or ϕ and \mathcal{S}). We observe that since π is subroutine respecting, the only way ITIs activated by the simulated $\tilde{\mathcal{Z}}$ may somehow share state information with the challenge instance of π is via access to the shared functionality $\bar{\mathcal{G}}$. Whenever

⁴Technically, we *must* modify the execution experiment here, since it is the environment which attempts to invoke the challenge protocol π , which is beyond the control of the adversary $\tilde{\mathcal{S}}$. Thus l and ϕ need to be specified as part of the execution experiment itself.

an ITI invoked by the internal simulation of \tilde{Z} wishes to communicate with $\bar{\mathcal{G}}$, \mathcal{Z}^* invokes a corresponding dummy party with the same pid and sid, and then forwards communications between the internally simulated ITI and the actual shared functionality $\bar{\mathcal{G}}$ in \mathcal{Z}^* 's external interaction via the dummy party. \mathcal{Z}^* then outputs whatever the internally simulated copy of \tilde{Z} outputs. This interaction results in the simulated \tilde{Z} operating with a view that corresponds to either EX_{l-1} or EX_l (which \tilde{Z} can distinguish with probability at least ϵ/m), and thus \mathcal{Z}^* successfully distinguishes with probability at least ϵ/m , as claimed, completing the contradiction. \square

We observe that if a protocol π does not use any shared functionalities (i.e., π is $\bar{\mathcal{G}}$ -subroutine respecting for a null functionality that generates no output) then a corollary of the above claim states that π UC-emulates ϕ if and only if π GUC-emulates ϕ . This equivalence shows the power of the basic UC emulation security guarantee, since it is indeed equivalent to the seemingly stronger notion of GUC emulation (for any protocols which exist in the more limited basic UC setting).

Universal Composition. Finally, we generalize the universal composition theorem to hold also with respect to GUC-emulation. That is, consider a $\bar{\mathcal{G}}$ -subroutine respecting protocol ϕ that is being used as a subroutine in some (arbitrary) larger protocol ρ . The new composition theorem guarantees that it is safe to replace a protocol ϕ with a different protocol π that merely $\bar{\mathcal{G}}$ -EUC-emulates ϕ , and yet the resulting implementation of ρ (which now invokes π instead of ϕ) will fully GUC-emulate the original version (which had invoked ϕ).

The formal composition theorem is stated in Theorem 2.3 above, which we now prove. The proof is similar in spirit to the proof of universal composition theorem (but here we no longer require the hybrid argument, since multiple protocol instances are already taken care of by the GUC setting).

Proof of Theorem 2.3. Since the notions of $\bar{\mathcal{G}}$ -EUC-emulation and GUC-emulation are equivalent for subroutine respecting protocols which do not use shared functionalities other than $\bar{\mathcal{G}}$, it suffices to prove that if π GUC-emulates ϕ then $\rho^{\pi/\phi}$ GUC-emulates ρ (of course, there is a corresponding loss of exact security as per Theorem 2.1). Thus, it suffices to prove that the composition theorem holds for subroutine respecting protocols that GUC-emulate each other. For the remainder of the proof, we shall refer to the “simulator \mathcal{S} ” as the “adversary”, in order to avoid confusion (roughly speaking, \mathcal{S} attempts to simulate the attack of an adversary, so this terminology is appropriate).

The proof that GUC-emulation is composable follows the same general approach as the composition theorem for basic UC in [12], with some simplifications resulting from the use of unconstrained environments. We begin by noting that there is an equivalent formulation of GUC-emulation with respect to dummy adversaries (the proof of this claim is entirely analogous to the proof of the same statement for basic UC security). Thus, denoting the dummy adversary by \mathcal{D} , we wish to construct an adversary \mathcal{A}_ρ such that

$$\text{GEXEC}_{\rho^{\pi/\phi}, \mathcal{D}, \mathcal{Z}} \approx \text{GEXEC}_{\rho, \mathcal{A}_\rho, \mathcal{Z}} \quad (1)$$

for any unconstrained environment \mathcal{Z} .

Since π GUC-emulates ϕ there is an adversary \mathcal{S} such that $\text{GEXEC}_{\pi, \mathcal{D}, \mathcal{Z}_\pi} \approx \text{GEXEC}_{\phi, \mathcal{S}, \mathcal{Z}_\pi}$ for any unconstrained environment \mathcal{Z}_π . That is, \mathcal{S} expects to interact with many instances of ϕ , with the goal of translating them to mimic the action of corresponding instances of π from the viewpoint of any environment \mathcal{Z}_π . We will use \mathcal{S} to construct \mathcal{A}_ρ satisfying (1) above. Unlike the construction in the basic UC composition theorem, it is not necessary for \mathcal{A}_ρ to run multiple copies

of \mathcal{S} (one for each session of π), since the GUC adversary \mathcal{S} already deals with the scenario where multiple sessions of π are executing (as unconstrained environments may invoke multiple instances of the challenge protocol). Thus the construction of \mathcal{A}_ρ here is simpler.

\mathcal{A}_ρ will simply run a single copy of \mathcal{S} internally, forwarding all messages intended for instances of π (which are sub-parties to instances of the challenge protocol ρ) sent by \mathcal{A}_ρ 's environment \mathcal{Z} to its internal simulation of \mathcal{S} , as well as forwarding any messages from \mathcal{S} back to \mathcal{Z} as is appropriate. (Note that \mathcal{A}_ρ need not simulate any interactions with instances of π that are invoked directly by \mathcal{Z} rather than an instance of ρ , since those are not associated with the challenge protocol.) Additionally, \mathcal{A}_ρ forwards \mathcal{S} 's interactions with instances of ϕ between the external instances of ϕ (again, only those which are sub-parties to instances of the challenge protocol ρ) and its internal copy of \mathcal{S} as well. (Intuitively, \mathcal{A}_ρ acts as the environment for \mathcal{S} by forwarding some of its own interactions with \mathcal{Z} concerning instances of π , and also copying its own interactions with external instances of ϕ . The reason \mathcal{S} is not employed directly in place of \mathcal{A}_ρ is that \mathcal{A}_ρ must translate the “challenge protocol” sessions ρ to isolate their sub-protocol invocations of ϕ , which is the challenge protocol \mathcal{S} expects to interact with. Thus, effectively, the instances of ρ itself simply become part of the environment for \mathcal{S} . Note that there may be many instances of ρ which are being translated, and each of those instances may invoke many instances of ϕ .)

In order to prove that \mathcal{A}_ρ satisfies (1) we perform a standard proof by contradiction. Assume there exists an environment \mathcal{Z} capable of distinguishing the interaction with \mathcal{A}_ρ and ρ from the interaction with \mathcal{D} and $\rho^{\pi/\phi}$. We show how to construct an environment \mathcal{Z}_π capable of distinguishing an interaction between \mathcal{S} and ϕ from an interaction with \mathcal{D} and π , contradicting the fact that π GUC-emulates ϕ .

The construction of \mathcal{Z}_π is again analogous to the technique applied in [12], with some additional simplification (since there is no hybrid argument here, we may simply treat all instances of ϕ the same way). As a useful tool in describing the construction of \mathcal{Z}_π , we briefly define an “internal simulation adversary” $\hat{\mathcal{A}}_\rho$, which will be run internally by \mathcal{Z}_π alongside an internally simulated copy of \mathcal{Z} . Whenever $\hat{\mathcal{A}}_\rho$ receives a message, it performs the same function as \mathcal{A}_ρ , only replacing \mathcal{A}_ρ 's communications with its internal simulation of the adversary \mathcal{S} (along with its corresponding challenge protocol ϕ) by communications with the external adversary for \mathcal{Z}_π (and its corresponding challenge protocol, which will either be π if the adversary is \mathcal{D} or ϕ if the adversary is \mathcal{S}). We observe that if \mathcal{Z}_π 's adversary is \mathcal{D} , then $\hat{\mathcal{A}}_\rho$ also acts like \mathcal{D} , since it will merely forward all messages. Similarly, if \mathcal{Z}_π 's external adversary is \mathcal{S} , then $\hat{\mathcal{A}}_\rho$ will function identically to \mathcal{A}_ρ .

On a high level, the environment \mathcal{Z}_π will internally simulate the environment \mathcal{Z} and adversary $\hat{\mathcal{A}}_\rho$, externally invoking copies of any ITIs that are invoked by the simulations (with the exception of instances of \mathcal{Z} 's challenge protocol π , and any invocations of \mathcal{Z}_π 's challenge protocol made by $\hat{\mathcal{A}}_\rho$), appropriately forwarding any messages between those ITIs and its internal copies of \mathcal{Z} and $\hat{\mathcal{A}}_\rho$. Whenever the internal copy of \mathcal{Z} wishes to invoke an instance of the challenge protocol ρ , the environment \mathcal{Z}_π internally simulates the instance (by modeling an ITI running ρ with the specified identity), forwarding any communications between ρ and shared functionalities to external instances of those shared functionalities (such forwarding may be accomplished by \mathcal{Z}_π externally invoking dummy parties the with same identities as the sub-parties of ρ that wish to communicate with the shared functionalities, and then forwarding communications through the dummy parties). Because ρ is subroutine respecting, it is safe to conduct such an internal simulation, as instance of ρ do not share state with any ITIs external to \mathcal{Z}_π except via the shared functionalities (which are handled

appropriately). Of course, whenever the internal simulation of \hat{A}_ρ wish to communicate with an instance of its challenge protocol, \mathcal{Z}_π will forward the communications to the correct instance of its own challenge protocol, as described above. When the internally simulated \mathcal{Z} halts and provides output, \mathcal{Z}_π similarly halts, copying the same output.

Now, we can observe that $\text{GEXEC}_{\pi, \mathcal{D}, \mathcal{Z}_\pi} = \text{GEXEC}_{\rho^{\pi/\phi}, \mathcal{D}, \mathcal{Z}}$ by considering that the internal simulation conducted by \mathcal{Z}_π will be a faithful recreation of the latter experiment. In particular, by its construction, the simulation of \hat{A}_ρ will simply act as the dummy adversary \mathcal{D} . Furthermore, the internal simulation of ρ is correctly replacing all invocations of ϕ by invocations of π (and thus is a perfect simulation of $\rho^{\pi/\phi}$), while the rest of the experiment proceeds identically. A similar argument yields that $\text{GEXEC}_{\phi, \mathcal{S}, \mathcal{Z}_\pi} = \text{GEXEC}_{\rho, \mathcal{A}_\rho, \mathcal{Z}}$. Previously, we assumed for the sake of contradiction that there exists an environment \mathcal{Z} such that $\text{GEXEC}_{\rho^{\pi/\phi}, \mathcal{D}, \mathcal{Z}} \not\approx \text{GEXEC}_{\rho, \mathcal{A}_\rho, \mathcal{Z}}$. Combining this statement with the previous two equations yields the result that there exists an environment \mathcal{Z}_π such that $\text{GEXEC}_{\pi, \mathcal{D}, \mathcal{Z}_\pi} \not\approx \text{GEXEC}_{\phi, \mathcal{S}, \mathcal{Z}_\pi}$, contradicting the fact that π GUC-emulates ϕ , completing our proof. \square

3 Insufficiency of the Global CRS Model

In this section we demonstrate that a global CRS setup is *not* sufficient to GUC-realize even the basic two-party commitment functionality. We then further elaborate the nature of this insufficiency by considering some weaknesses in the security of previously proposed constructions in the CRS model. Finally, we suggest a new “intuitive” security goal, dubbed *full simulatability*, which we would like to achieve by utilizing the GUC-security model (and which was not previously achieved by any protocols in the CRS model).

3.1 Impossibility of GUC-realizing \mathcal{F}_{com} in the $\bar{\mathcal{G}}_{crs}$ model

This section shows that the simple CRS model is insufficient for GUC-realizing \mathcal{F}_{com} . Let us elaborate.

Recall that many interesting functionalities are unrealizable in the UC framework without any setup assumption. For instance, it is easy to see that the ideal authentication functionality, \mathcal{F}_{auth} , is unrealizable in the plain model. Furthermore, many two party tasks, such as Commitment, Zero-Knowledge, Coin-Tossing, Oblivious Transfer and others cannot be realized in the UC framework by two-party protocols, even if authenticated communication is provided [16, 17, 11].

As a recourse, the common reference string (CRS) model was used to re-assert the general feasibility results of [26] in the UC framework. That is, it was shown that any “well-formed” ideal functionality can be realized in the CRS model [16, 18]. However, the formulation of the CRS model in these works postulates a setting where the reference string is given *only to the participants in the actual protocol execution*. That is, the reference string is chosen by an ideal functionality, \mathcal{F}_{crs} , that is dedicated to a given protocol execution. \mathcal{F}_{crs} gives the reference string only to the adversary and the participants in that execution. Intuitively, this formulation means that, while the reference string need not be kept secret to guarantee security, it cannot be safely used by other protocol executions. In other words, no security guarantees are given with respect to executions that use a reference string that was obtained from another execution rather than from a dedicated instance of \mathcal{F}_{crs} . (The UC with joint state theorem of [19] allows multiple executions of certain protocols

to use the same instance of the CRS, but it requires all instances that use the CRS to be carefully designed to satisfy some special properties.)

In contrast, we are interested in modeling a setting where the same CRS is globally available to all parties and all protocol executions. This means that a protocol π that uses the CRS must take into account the fact that the same CRS may be used by *arbitrary* other protocols, even protocols that were specifically designed to interact badly with π . Using the GUC security model defined in Section 2, we define this weaker setup assumption as a *shared* ideal functionality that provides the value of the CRS not only to the parties of a given protocol execution, but rather to all parties, and even directly to the environment machine. In particular, this global CRS functionality, $\bar{\mathcal{G}}_{crs}$, exists in the system both as part of the protocol execution and as part of the ideal process. Functionality $\bar{\mathcal{G}}_{crs}$ is presented in Figure 3.

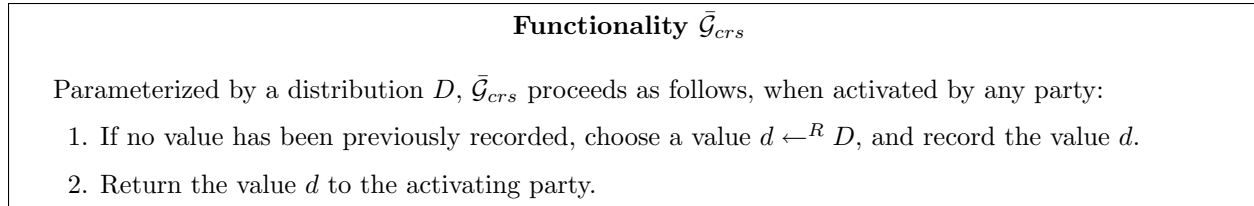

Figure 3: The Global Common Reference String functionality. The difference from the Common Reference String functionality \mathcal{F}_{crs} of [11, 16] is that \mathcal{F}_{crs} provides the reference string only to the parties that take part in the actual protocol execution. In particular, the environment does not have direct access to the reference string.

We demonstrate that $\bar{\mathcal{G}}_{crs}$ is insufficient for reproducing the general feasibility results that are known to hold in the \mathcal{F}_{crs} model. To exemplify this fact, we show that no two-party protocol that uses $\bar{\mathcal{G}}_{crs}$ as its only setup assumption GUC-realizes the ideal commitment functionality, \mathcal{F}_{com} (presented in Figure 4). The proof follows essentially the same steps as the [16] proof of impossibility of realizing \mathcal{F}_{com} in the plain model. The reason that these steps can be carried out even in the presence of $\bar{\mathcal{G}}_{crs}$ is, essentially, that the simulator obtains the reference string from an external entity ($\bar{\mathcal{G}}_{crs}$), rather than generating the reference string by itself. We conjecture that most other impossibility results for UC security in the plain model can be extended in the same way to hold for GUC security in the presence of $\bar{\mathcal{G}}_{crs}$.

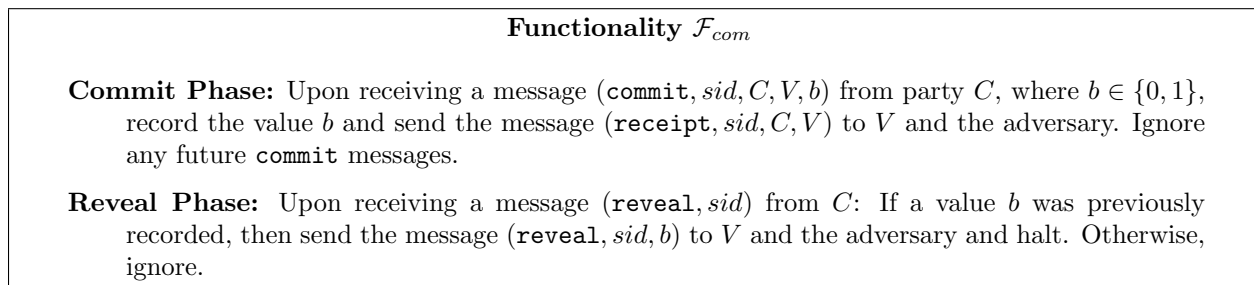

Figure 4: The Commitment Functionality \mathcal{F}_{com} (see [16])

Theorem 3.1. *There exists no bilateral, terminating protocol π that GUC-realizes \mathcal{F}_{com} and uses only the shared functionality $\bar{\mathcal{G}}_{crs}$. This holds even if the communication is ideally authentic.*

Proof. Intuitively, the proof of the impossibility of UC commitments (for the plain model) described in [16] holds here as well, since an $\bar{\mathcal{G}}_{crs}$ -externally constrained environment \mathcal{Z} is able to obtain a copy of the global CRS directly from $\bar{\mathcal{G}}_{crs}$ (by invoking any dummy party specifically to obtain the reference string), preventing the simulator \mathcal{S} from choosing its own (trapdoored) CRS.

More formally, suppose that there exists a commitment protocol π (for a party P_i committing a bit b to a party P_j) and a simulator \mathcal{S} such that $\text{EXEC}_{\mathcal{F}_{com}, \mathcal{S}, \mathcal{Z}} \approx \text{EXEC}_{\pi, \mathcal{A}, \mathcal{Z}}$ for any adversary \mathcal{A} and any $\bar{\mathcal{G}}_{crs}$ -externally constrained environment \mathcal{Z} (here we may even allow \mathcal{S} to depend on the choice of \mathcal{A} and \mathcal{Z}). We will arrive at a contradiction.

We accomplish this by constructing a new $\bar{\mathcal{G}}_{crs}$ -externally constrained environment \mathcal{Z}' and a new adversary \mathcal{A}' such that there is *no* simulator \mathcal{S}' which can satisfy $\text{EXEC}_{\mathcal{F}_{com}, \mathcal{S}', \mathcal{Z}'} \approx \text{EXEC}_{\pi, \mathcal{A}', \mathcal{Z}'}$. Recall that an $\bar{\mathcal{G}}_{crs}$ -externally constrained environment may invoke dummy parties running $\text{IDEAL}_{\bar{\mathcal{G}}_{crs}}$ using any unique (pid, sid), and thus may obtain a copy of the global CRS.

Our \mathcal{A}' is constructed so as to corrupt the recipient P_j at the beginning of the protocol. During the protocol, \mathcal{A}' will run the algorithm for \mathcal{S} using the same CRS as obtained from $\bar{\mathcal{G}}_{crs}$ (via \mathcal{Z}') to respond to all of \mathcal{S} 's $\bar{\mathcal{G}}_{crs}$ queries, and using the same party and session identities for P_i and P_j in this “virtual” run of \mathcal{S} . Furthermore, while acting as the environment for this copy of \mathcal{S} , \mathcal{A}' will “corrupt” the party “ P_i ” in the virtual view of \mathcal{S} . Whenever \mathcal{A}' receives protocol messages from the honest party P_i in the real protocol execution, it sends the same messages on behalf of the “corrupt party P_i ” in the virtual view of \mathcal{S} . Whatever messages \mathcal{S} would send on behalf of the “honest” virtual recipient “ P_j ”, \mathcal{A}' will send on behalf of the real party P_j (which it has previously corrupted). At some point, \mathcal{S} must send the message $(\text{commit}, \text{sid}, P_i, P_j, b')$ to the commitment functionality. At this point, the adversary \mathcal{A}' will output the bit b' , and halt.

We define the environment \mathcal{Z}' to choose a random bit b , and provide it as the input for the honest committer P_i . If the adversary outputs b' such that $b' = b$, then \mathcal{Z}' outputs 1 (and 0 otherwise). (Additionally, we implement any trivial interface for \mathcal{Z}' to pass a copy of the CRS to \mathcal{A}' .) Observe that no decommitment ever occurs, and thus the view of \mathcal{S}' must be independent of the choice of b (meaning that \mathcal{S}' must be correct with probability 1/2). However, as \mathcal{S} must produce a bit b' that matches b with all but negligible probability (since we assumed it simulates the protocol π correctly), \mathcal{A}' 's guess b' must match b with high probability, and thus \mathcal{Z}' will clearly distinguish between the guesses of \mathcal{A}' and those of \mathcal{S}' (which are correct with probability exactly 1/2). □

In fact, it is easy to see that the above impossibility result extends beyond the mere availability of $\bar{\mathcal{G}}_{crs}$ to any circumstance where the shared functionality will only provide information globally (or, yet more generally, the impossibility holds whenever all the shared information available to protocol participants can also be obtained by the environment). For instance, this impossibility will hold even in the (public) random oracle model, which is already so strong that it cannot truly be realized without the use of a fully interactive trusted party. Another interpretation of this result is that no completely *non-interactive* global setup can suffice for realizing \mathcal{F}_{com} . The next section studies the problem of realizing \mathcal{F}_{com} using setup assumptions with minimal interaction requirements.

3.2 Deniability and Full Simulatability

To demonstrate that the problems with using a global CRS to realize \mathcal{F}_{com} , in the fashion of [18], are more than skin deep technicalities that arise only in the GUC framework we now consider the issue of deniability. Intuitively, a protocol is said to be “deniable” if it is possible for protocol participants to deny their participation in a protocol session by arguing that any “evidence” of their participation (as obtained by other, potentially corrupt protocol participants) could have been fabricated.

Recalling the intuition outlined in the introduction, we would like realized protocols to guarantee the same security as the ideal functionalities they realize, meaning that the adversary will learn nothing more from attacking the protocol than could be learned from attacking its corresponding ideal functionality. Protocols realized with such a guarantee are inherently *deniable*, since a protocol participant can accurately argue that any information sent during the protocol session could have been obtained by an adversary using only the output from the ideal functionality⁵ in an attack simulation conducted entirely without his or her actual participation.

For instance, if we consider the ideal functionality for Zero Knowledge (ZK), we expect that any secure realization of that functionality should reveal no information to the adversary beyond the output of the ideal functionality (which contains no information at all). In particular, the ideal functionality output easily be generated entirely without the help of the prover, and thus the prover should be able to deny his participation in any proof protocols, since they reveal no information that could not have been obtained independently. However, we already know from the result of [33] that it is impossible to achieve such deniability for ZK in the CRS model. Indeed, we may see that the UC simulator for ZK functionality in [18] chooses a fresh CRS, and generates the simulated protocol transcripts with respect to that, instead of the published real-world CRS. Thus, if a protocol transcript makes use of the real-world CRS, it could not have been obtained via simulation (so a successful prover is indeed incriminated by the transcript).

When there is no deniability, the adversary is truly able to obtain some valuable information from observing a protocol interaction that it could not have obtained by attacking the ideal functionality. Thus we have found a practical example of an actual loss of security that is a direct result of the relaxations of UC security inherent in the CRS technique of [18]. We can now clearly see that the impossibility of realizing \mathcal{F}_{com} via the CRS model in the GUC setting is due to a meaningful strengthening of security guarantees (since deniability is guaranteed in the GUC setting, and that guarantee is not achieved by protocols realized in the CRS model).

On an intuitive level, it might be helpful to consider the issue of deniability in light of the “real world” resources required in order to run the GUC simulator to simulate a given protocol session. If the resources required to simulate a protocol session are readily available, then we say the protocol session is *plausibly deniable* (since it is plausible that information obtained from the protocol was the result of a simulation). If the resources required to simulate are difficult or impossible to obtain, then there is no guarantee of plausible deniability (since it will be difficult to convince others that an incriminating protocol transcript was the result of a simulation). We wish to employ simulation techniques that require only minimal resources to conduct a simulation, increasing the plausibility

⁵Of course, if the output of the ideal functionality “incriminates” a user by revealing some of his secrets, the resulting protocol does not meet our intuitive understanding of the word “deniable”. Still, the protocol itself may be said to be “as deniable” as the functionality it realizes.

of denials (as well as decreasing the value of any information that an adversary might obtain by attacking a secure protocol). Thus, we use the term *fully simulatable* to refer to any plausibly deniable protocol realized in the GUC framework.

From this vantage point, we observe that the resource required to conduct the protocol simulations in [18] is the “trapdoor” for the CRS. In particular, the CRS must be “rigged” with such a trapdoor *a priori*. Such rigging is certainly not at all plausible when there is a trusted party choosing the CRS, and this is in fact the root of the deniability problem for the CRS model. Furthermore, knowledge of this trapdoor implies the ability to completely violate security of any protocol constructed using the techniques of [18], and thus there would be no security against any entity capable of simulating protocols. Similarly, in the “imaginary angel” model of [35], the simulator requires access to super-polynomial time functionalities that are certainly not plausibly available in the real world (and thus, the deniability problem arises there as well). Indeed, if the “imaginary angels” of [35] were to somehow be made practical in the real world, all security would be lost.

We comment that, although we do not make any attempt to formalize a “general” notion of deniability here, the guarantee we seek to provide is that protocols are “as deniable” in the real world as they would have been in the ideal world (past works did not satisfy even this basic requirement). In fact, as will be demonstrated shortly, our particular realization of fully simulatable security will guarantee that even “on line” (interactive) deniability is preserved, since the simulator can very practically be run in real time. Indeed, as long as an honest party P never deviates from the protocol, it is not possible for other (even corrupt) protocol participants to conclusively demonstrate P ’s participation in the fully simulatable protocol session to a third party, *even while the protocol is ongoing!*

4 Fully Simulatable General Computation

We now turn our attention to the problem of *constructing* fully simulatable GUC-secure protocols. That is, we would like it to be possible for any adversary to actually simulate the effects of any attack on our real-world protocol (in a computationally indistinguishable manner), without actually conducting the attack on the protocol (instead utilizing only the information that would be revealed by an ideally secure realization of said protocol). The impossibility result of Section 3 implies that we cannot do this in the standard CRS model (if we correctly model the global availability of the CRS). Thus, we must consider alternatives to the CRS model if we hope to achieve our goal.

Since we must somehow avoid the impossibility result of Section 3 for the CRS model, we would like to find reasonable alternative global setup assumptions that allow for realizing interesting tasks. That is, we are looking for shared ideal functionalities $\bar{\mathcal{G}}$ (as defined in Section 2), so that on the one hand $\bar{\mathcal{G}}$ will be implementable in reality with reasonable trust assumptions, and on the other hand we will have protocols that GUC-realize interesting functionalities and still use no setup (i.e., no ideal functionalities) other than $\bar{\mathcal{G}}$. We say that such GUC-secure protocols are “fully simulatable” since the GUC-simulator for attacking the ideal protocol can, in a very practical sense, be run directly by the adversary. This allows the adversary to obtain *the same information* that can be gotten by attacking any session of the real protocol, without the need to actually perform an attack. (Of course, this information is also inherently useless to the adversary, since the ideal protocol attacked by the simulation is perfectly secure.)

We first observe that if the system is equipped with a “fully interactive trusted party” that realizes, say, \mathcal{F}_{mcom} , the multi-session variant of \mathcal{F}_{com} , by interacting separately and privately with each session, then we can directly use the protocol of [18] to GUC-realize any “well-formed” functionality. However, we would like to find more reasonable global setup assumptions, and in particular assumptions that require less interaction from the trusted entity. (Indeed, this realization requires the trusted party to perform strictly more work than it would by directly computing the desired functionalities, *i.e.* the trivial realization of ideal model functionalities). Although it is clear that we can achieve fully simulatable protocols by using highly interactive trusted parties to compute functionalities, it seems to be a more difficult problem to realize GUC-secure protocols using an “offline” shared functionality. Indeed, by our earlier impossibility results, *some* degree of interaction would seem to be essential, so we begin by considering the idea of limiting the interaction to a “registration phase”.

4.1 The KRK Model

We observe that the “key registration with knowledge (KRK)” setup of [5], can be modified to serve as a shared ideal functionality, allowing us to realize any “well-formed” ideal functionality against non-adaptive (“static”) adversaries using the techniques of that work. Although the setup phase is interactive (parties must register their public keys with registration authorities), it is possible to show (with some minor modifications) that the protocol of [5] can allow the trusted party to remain “offline” for all subsequent protocol activity.

Functionality \mathcal{G}_{krk}
<p>\mathcal{G}_{krk} proceeds as follows, given a (deterministic) key generation function Gen (with security parameter λ), running with parties P_1, \dots, P_n and an adversary \mathcal{S}:</p> <p>Registration: When receiving a message (register, sid, r) from party P_i that has not previously registered, compute $(PK_i, SK_i) \leftarrow \text{Gen}^\lambda(r)$ and record the tuple (P_i, PK_i, SK_i).</p> <p>Retrieval: When receiving a message (retrieve, sid, P_j) from party P_j (where $j \neq i$), if there is a previously recorded tuple of the form (P_i, PK_i, SK_i), then return (sid, P_i, PK_i) to P_j. Otherwise return (sid, P_i, \perp) to P_j. When receiving a message (retrieve, sid, P_i) from party P_i, if there is a previously recorded tuple of the form (P_i, PK_i, SK_i), then return (sid, P_i, PK_i, SK_i) to P_i. Otherwise, return (sid, P_i, \perp) to P_i.</p>

Figure 5: The Knowledge-based Key Registration Functionality (similar to that of [5]). Note that each instance of \mathcal{G}_{krk} can only be invoked by the parties of a single protocol session (*i.e.* with a fixed sid). After converting this ideal functionality to a shared functionality, $\bar{\mathcal{G}}_{krk}$, and restricting retrieval of private keys to *corrupt parties only*, it is possible GUC-realize any functionality using only a single public key per-party.

Recall that the KRK setup of [5] is an ideal functionality \mathcal{G}_{krk} (shown in Figure 5), that chooses a private and public key pair for each registered party (namely, each registered ITI), and lets all parties know the value of the public key. In the natural version of the KRK setup, parties are also allowed to retrieve their own secret keys. Since \mathcal{G}_{krk} is not a shared functionality, we have that each instance of a protocol has its own instance of \mathcal{G}_{krk} , which does not lend itself to easy implementation. To fix this, we re-formulate \mathcal{G}_{krk} as a shared functionality, $\bar{\mathcal{G}}_{krk}$, that chooses a

public key *per PID* rather than per ITI – that is, all ITIs that have the same PID also have the same public key. Furthermore, we add a simple modeling restriction: we only allow parties to learn their own secret keys if they are corrupt.⁶ This modeling makes $\bar{\mathcal{G}}_{krk}$ significantly easier to implement in a real system, since only one key is required for each party. Using this new $\bar{\mathcal{G}}_{krk}$ setup, the protocol of [5] works (with minor modifications) even in the GUC-security model, provided that (a) party corruptions are non-adaptive, and (b) all parties with the same PID are corrupted together – we call such corruption pattern *PID-wise*.

Theorem 4.1. *The [5] protocol GUC-realizes \mathcal{F}_{zk} , even when given access only to $\bar{\mathcal{G}}_{krk}$, as long as the party corruptions are non-adaptive and PID-wise.*

The proof of this theorem is by a natural extension of the proof in [5] to the EUC framework (which is, of course, equivalent to GUC), but surprisingly, we can achieve a much stronger goal than non-adaptive GUC security with interactive setup.

4.2 The Augmented CRS Model

Although it may seem that *at least* an interactive “registration phase” is required in order to avoid our earlier impossibility result, we show that something even *less interactive* will suffice. We propose a further simplification of $\bar{\mathcal{G}}_{krk}$, denoted $\bar{\mathcal{G}}_{acrs}$, and a protocol that GUC-realizes \mathcal{F}_{com} (and thus any well-formed functionality) having access only to $\bar{\mathcal{G}}_{acrs}$. Unlike $\bar{\mathcal{G}}_{krk}$, the $\bar{\mathcal{G}}_{acrs}$ shared functionality does not *require* any interaction (much like \mathcal{F}_{crs}), but merely offers a one-time use interactive “key retrieval” service to those who choose to use it. Therefore, we refer to this new setup assumption as the *Augmented CRS* (ACRS) model. In particular, protocols realized in the ACRS model will not actually make use of the key retrieval service, since the model only allows corrupt parties to retrieve their keys. Thus, we are assured that honest parties need never communicate interactively with $\bar{\mathcal{G}}_{acrs}$.

Somewhat counter-intuitively, it is even crucial that uncorrupted parties in ACRS model never “bother” to obtain their secret keys from the trusted authority (since even an honest party may inadvertently execute a rogue protocol, which might expose the secret key). Similarly, it is crucial that the corrupted parties have access to their secret keys, otherwise they would be unable to conduct attack simulations. (On a side note, security is still guaranteed to honest parties who wish to obtain their keys and use them to conduct attack simulations *provided that they only* use their keys for simulation purposes. This is a direct consequence of the “equivalence” between the information revealed by attack simulations, and the information that can be obtained via real-world attacks.) To enforce the protocol design criteria that honest parties should not require access to their secret keys, we directly define the $\bar{\mathcal{G}}_{acrs}$ functionality so that it refuses to supply secret keys to honest parties. (Of course, a direct realization of $\bar{\mathcal{G}}_{acrs}$ by a trusted party cannot actually determine which parties are honest, yet intuitively this modeling should still suffice. In fact, it is not problematic even if the real-world trusted party gives keys to honest parties, since honest parties will be careful not to use their secret keys in protocols, as doing so would only serve to harm one’s own security.)

More formally, our new shared functionality $\bar{\mathcal{G}}_{acrs}$ is parameterized by two functions, **Setup** and **Extract**. It first chooses a random secret value MSK and a public value $PK \leftarrow \text{Setup}(MSK)$,

⁶The reason for this restriction, and its meaning, will be discussed in further detail in Section 4.2.

and publicizes PK (as a CRS). Next, whenever a *corrupted* party with PID pid asks for its secret key, $\bar{\mathcal{G}}_{acrs}$ returns the value $SK_{pid} \leftarrow \text{Extract}(PK; pid; MSK)$. The functionality is presented in Figure 6.

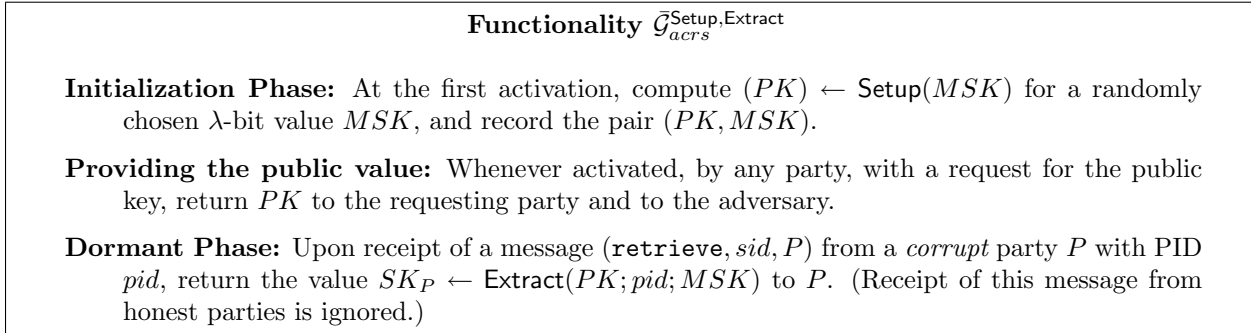

Figure 6: The Identity-Based Augmented CRS Functionality

Comparing $\bar{\mathcal{G}}_{krk}$ and $\bar{\mathcal{G}}_{acrs}$. The main difference between $\bar{\mathcal{G}}_{acrs}$ and $\bar{\mathcal{G}}_{krk}$ (the global variant of \mathcal{G}_{krk}) is that in $\bar{\mathcal{G}}_{acrs}$ there is a single public value, whereas in $\bar{\mathcal{G}}_{krk}$ an extra public value must be given per party identity. Using a paradigm analogous to the identity-based encryption of [6], we avoid the use of per-party public keys and replace them with a single *short* “master public key” (and indeed our constructions use short public keys that depend only on the security parameter). This property, combined with the fact that the parties who follow their protocols never obtain their secret keys, makes $\bar{\mathcal{G}}_{acrs}$ very close in spirit to a global CRS setup as in $\bar{\mathcal{G}}_{crs}$. In fact, in light of the far-reaching impossibility result for $\bar{\mathcal{G}}_{crs}$, $\bar{\mathcal{G}}_{acrs}$ can be regarded as a “minimum interaction” global setup.

We note that, as pointed out in [5], $\bar{\mathcal{G}}_{krk}$ can be naturally implemented by multiple “registration authorities”, where no single authority needs to be fully trusted by all. (However, we once again stress that $\bar{\mathcal{G}}_{krk}$ requires *all* parties, *even those who honestly follow their protocols*, to interactively register with a *some* authority and obtain a public key.) Similarly, although $\bar{\mathcal{G}}_{acrs}$ with a short public key would naturally seem to call for a realization by a single trusted entity, the same technique applies and several instances of $\bar{\mathcal{G}}_{acrs}$ may be run by different trusted authorities. Unlike $\bar{\mathcal{G}}_{krk}$, however, parties may participate in protocols while placing their trust in an arbitrary trusted authority, without ever having registered with *any* authority. This is extremely useful for settings where PKIs are not desirable or easy to implement, and where no single “global” authority is available (see *e.g.* [4]).⁷

In the next section, we will prove the following result:

⁷In fact, the protocol we will describe in Section 5 can also support a “graceful failure” approach similar to that outlined in [5], in the scenario where protocol participants do not mutually trust any single authority. That is, by using suitable “graceful” tools (in the case of our protocol, a “graceful” IBTC), we can ensure full GUC security if trustworthy authorities are used by all parties, and ordinary stand-alone security for party P in the case where only party P ’s authority is trustworthy (even if party P ’s own authority is made completely unavailable after publishing its reference string and/or is later corrupted subsequent to the completion of the protocol!). The proof of this claim is a straightforward consequence of our protocol in Section 5, combined with the fact that our IBTC construction in Section 5.2 guarantees hiding even for maliciously chosen public keys (as long as it remains possible to verify the existence of the Σ -protocol with HVZK property for the signature scheme). Of course, all IBTCs addressed to party P should make use of the reference string published by the authority that P trusts.

Theorem 4.2. *There exists a protocol that GUC-realizes \mathcal{F}_{com} given access to $\bar{\mathcal{G}}_{acrs}$. Party corruptions can be adaptive (and in the non-erasure model), as long as they are PID-wise.*

Finally, we note that a GUC secure realization of \mathcal{F}_{com} is indeed sufficient to GUC-realize any “well-formed” *multi-party* functionality. This may be accomplished by first using \mathcal{F}_{com} to realize \mathcal{F}_{zk} (as in [18]), and then using \mathcal{F}_{zk} to realize the “one-to-many” Zero-Knowledge functionality, $\mathcal{F}_{zk}^{1:M}$ (via the technique of [34]). The multi-party protocol compiler from [18] can then be used to yield a UC-secure realization of any well-formed multi-party functionality in the $\mathcal{F}_{zk}^{1:M}$ -hybrid model without using any further shared state (thus it is also a GUC-secure realization).

5 GUC-Realizing \mathcal{F}_{com} using the $\bar{\mathcal{G}}_{acrs}$ Global Setup

We now describe the construction of a protocol satisfying the conditions of Theorem 4.2, above. When combined with the compiler from [18], such a *fully simulatable* realization of \mathcal{F}_{com} yields a fully simulatable realization of any well-formed two-party or multi-party functionality. Furthermore, we show that, in addition to requiring only the more minimal $\bar{\mathcal{G}}_{acrs}$ setup, our protocol achieves significantly stronger properties than the fully simulatable protocol from [5] realized in the $\bar{\mathcal{G}}_{krk}$ model. (Of course, our protocol can also be trivially modified for use in the $\bar{\mathcal{G}}_{krk}$ model, where it will enjoy the same strengthened security guarantees.)

Firstly, our protocol realizing \mathcal{F}_{com} in the $\bar{\mathcal{G}}_{acrs}$ model remains secure even in the presence of adaptive corruptions (which the protocol of [5] cannot achieve). Intuitively, adaptive security seems to be difficult to attain in either the $\bar{\mathcal{G}}_{krk}$ or $\bar{\mathcal{G}}_{acrs}$ models, since an adaptive adversary is eventually able to learn nearly all secrets in the system (save only for the random coins of the trusted party). Since the simulator relies on these same secrets to “break” privacy of (corrupt) parties during attack simulations, it would seem that an adversary provided with access to *all* secrets should be able to violate the privacy of past protocol transcripts. Our protocol manages to avoid this problem through the use of some additional interactivity.

Remarkably, our protocol for realizing \mathcal{F}_{com} will also maintain security of past protocol executions even if the trusted party implementing $\bar{\mathcal{G}}_{acrs}$ is later corrupted (even revealing the random coins used to generate the CRS, which leaves the overall system with no secrets at all). That is, our protocol will guarantee that past transcripts of protocol interactions can never be used to compromise the security or deniability of honest parties *even if the trusted party is later corrupted*. Security is only lost when the trusted party acts maliciously *prior to*, or *during* protocol execution. This kind of “forward security” with respect to the trusted party further minimizes the trust assumptions required to realize $\bar{\mathcal{G}}_{acrs}$ in the real-world. For instance, an adversary cannot eventually coerce the trusted party into breaking the security of an honest party after the completion of the protocol. Such forward security cannot be achieved using the protocol of [5] since knowledge of the secret key allows “extraction” from past commitments, breaking privacy. In fact, even the protocol of [18] loses all privacy in past transcripts if the trusted party implementing the CRS setup later reveals a trapdoor.

5.1 High-level description of the protocol

Our protocol for realizing \mathcal{F}_{com} in the $\bar{\mathcal{G}}_{acrs}$ shared hybrid model, which we call Protocol UAIBC (for UC Adaptive Identity-Based Commitment), relies on two new techniques. First, we construct an *identity-based* trapdoor commitment (IBTC) which enjoys adaptive security. Then we provide a general transformation from any IBTC into a protocol that securely implements \mathcal{F}_{com} .

Constructing IBTC. In the setting of IBTC a single “master-key” is made public. Additionally, all parties can obtain a private-key that is associated to their party identifier. (Note that this setting corresponds exactly to the interface of $\bar{\mathcal{G}}_{acrs}$.) Intuitively, an IBTC is a commitment scheme with the additional property that a committer which *knows* the receiver’s secret-key can *equivocate* commitments (i.e., it can open up commitments to any value, breaking the binding property of the commitment). Furthermore, it should hold that an adversary that obtains the secret-keys of multiple parties, still should not be able to violate the binding property of commitments sent to parties for which it has not obtained the secret-key.

Constructions of IBTCs were previously known in the Random Oracle Model [1, 37]. Here we provide a conceptually simple approach to constructing an adaptively secure IBTC from any one-way function, in the standard model. Our approach relies on the use of Sigma protocols [14], in an approach based on that of [22] (and perhaps surprisingly can result in a very practical protocol). On a very high-level (and very oversimplified) the general idea is as follows: 1) let the master-key be a public-key for a signature scheme, 2) let the secret-key for a party be a signature on its party identifier, and 3) construct a commitment scheme where the reveal phase consists of a “proof” that *either* the revealed value is consistent with the value committed to, *or* the committer knows a signature on the receiver’s party identifier (this “proof” must also “hide” which of these two statements actually holds). We mention that the actual instantiation of this idea is somewhat more involved, in order to guarantee adaptive security, and we provide the full details of our construction in Section 5.2.

From IBTC to GUC Commitments. Recall that a protocol for realizing \mathcal{F}_{com} must intuitively satisfy two properties (in addition to the traditional binding and hiding properties of any commitment scheme): 1) it must be equivocable, and 2) it must be extractable. We show how to transform any “equivocable” commitment scheme (such as an IBTC) into a protocol for securely realizing \mathcal{F}_{com} (for single bit commitments). Previously similar types of transformations have appeared in the literature (e.g., [18], [7]). Unfortunately all such transformations either require some additional *non-global* setup (and are thus not applicable in our setting), or only work in the case of static security. We now turn our focus to the protocol UAIBC, which GUC-realizes the \mathcal{F}_{com} functionality via a novel transformation of an IBTC from a mere equivocable commitment (in the standard model), to an equivocable *and* extractable commitment secure against adaptive corruptions in the GUC-security model. We remark that our transformation technique can be employed by substituting *any* merely equivocable commitment scheme (such as standard public key based trapdoor commitments) in place of the IBTC in our protocol, and will yield a scheme that is both equivocable and extractable, a general approach that may prove useful in many other contexts.

We now describe some of the details and intuition for our protocol UAIBC. We will show that UAIBC realizes the \mathcal{F}_{com} ideal functionality in a *fully simulatable* manner (even against adaptive

adversaries in the non-erasure setting). Furthermore, the protocol UAIBC is *forward secure*, so that past protocol sessions will remain secure even if the trusted party implementing $\bar{\mathcal{G}}_{acrs}$ is later corrupted. We refer to this latter property as “strong full simulatability”, since the output transcript of a GUC-simulation will be indistinguishable from a real transcript even to parties in possession of all keys (indeed, even if the parties possess all the random coins used to generate the CRS!). The protocol is given in the combined secure and authenticated channels model (formally denoted as the \mathcal{F}_{smt} and \mathcal{F}_{auth} hybrid models, respectively). In particular, UC-secure channels are used crucially in the proof of security of UAIBC, detailed in Section 5.

On a high-level, protocol UAIBC proceeds as follows. The committer P_i and receiver P_j first perform a coin-tossing to generate a public-key K for a dense crypto-system. This coin-tossing requires the receiver to use an IBTC, and has the property that if the committer is corrupted, the outcome of the coin-tossing can be set to any value. After a completed coin-tossing, the committer commits to a single bit b using an IBTC (let c denote this commitment), and additionally sends an auxiliary string e : e is either a random string in case $b = 1$, and an encryption to the decommitment information of c if $b = 0$. (We here require that the encryption scheme used has *pseudo-random ciphertexts*.) In the reveal phase, the committer is required to provide correct decommitment information for c , and additionally reveal the value encrypted in e in case $b = 0$. We graphically illustrate the operation of this protocol in Figure 7.

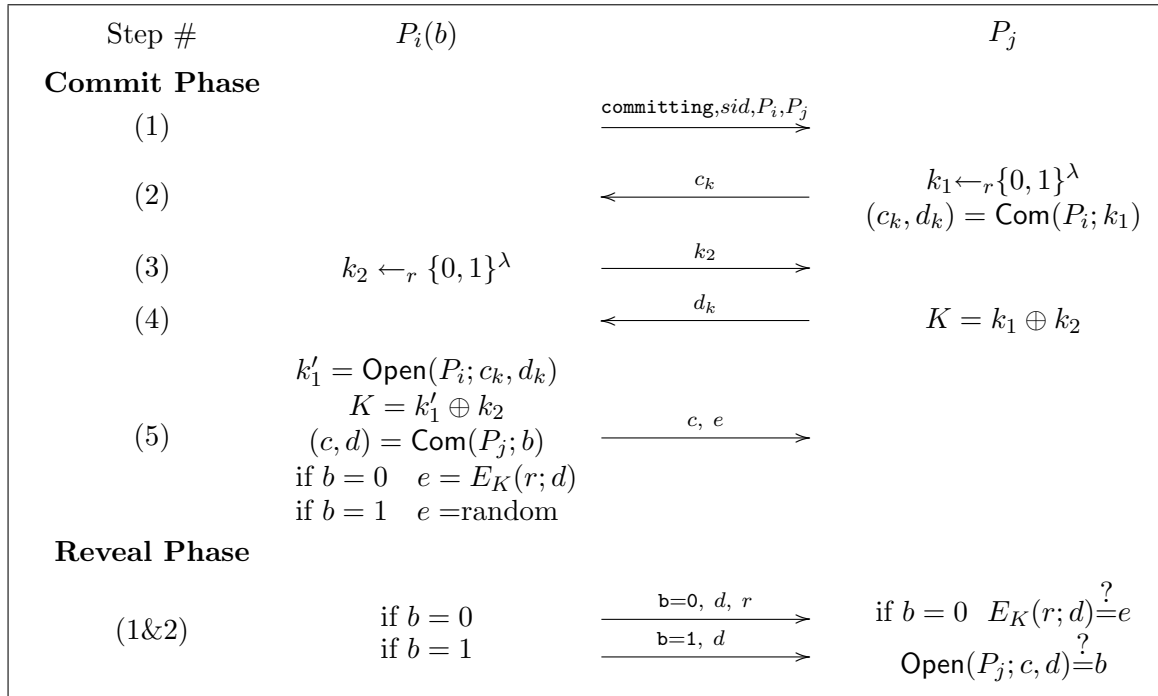

Figure 7: Operation of Protocol UAIBC, with party P_i committing bit b to party P_j . Note that Com and Open are operations for an IBTC (the first input is the identity of the recipient), and E_K is a Dense OT-PRC secure encryption using key K (the first input is the random coins fed to the encryption operation, and the second is the plaintext). Steps 2 to 4 of the **Commit** phase are essentially a coin-tossing protocol, whereas the subsequent steps are similar to the protocol of [18].

We now take a brief detour to specify the security properties of the IBTC scheme and the dense crypto-system required by our protocol, before proceeding with more in-depth discussion of the protocol.

5.2 Identity-based Trapdoor Commitments

The tool we now define, which we dub Identity-based Trapdoor Commitments (IBTCs), represents a slight generalization of the identity-based chameleon hash functions first introduced in [1]. Any Identity-Based Chameleon Hash function is sufficient (but not *necessary*) to yield an IBTC. We introduce IBTCs in order to accommodate our suggested constructions in Section 4.

Definition 3 (IBTC). *An Identity-based Trapdoor Commitment scheme IC is given by a 6-tuple of PPT algorithms, $IC = (\text{Setup}, \text{Extract}, \text{Com}, \text{Open}, \text{ECom}, \text{Eqv})$, with the following basic properties:*

- **Setup:** On input 1^λ outputs a public key PK and a master secret key MSK containing all random coins used by **Setup**, with “security parameter” λ . We may omit explicit mention of PK (which is always used as an input for the remaining algorithms) as a notational convenience. We emphasize that MSK should contain all the random coins used by **Setup**, which may not be a natural requirement (we require this only to prove the forward security property of *strong* full simulatability).
- **Extract:** On input $(PK; ID; MSK)$ outputs a trapdoor SK_{ID} for identity ID .
- **Com:** On input $(s; PK; ID; m)$ outputs a commitment/decommitment pair (c, d) for message m under identity ID using random coins s . Note that **Com** is a deterministic operation for fixed choice of s , and as a notational convenience, whenever s is not explicitly specified it is chosen uniformly at random. We denote the domain from which s is chosen by \mathcal{S} .
- **Open:** On input $(PK; ID; c, d)$ returns a message m or \perp (invalid). Correctness requires that $\text{Open}(PK; ID; \text{Com}(ID; m)) = m$ for any choice of ID and m .
- **ECom:** On input $(PK; ID; SK_{ID})$ outputs a pair (c, α) , to be used with **Eqv**.
- **Eqv:** On input $(PK; ID; SK_{ID}, c, \alpha, m)$ produces coins s (indistinguishable from random) such that $\text{Com}(s; PK; ID; m) = (c, d)$ (and thus $\text{Open}(PK; ID; (c, d)) = m$).

The formal security properties of Identity-based Trapdoor Commitments are given below. Roughly speaking, they consist of three natural computational security properties known as hiding, binding, and equivocability. The hiding property requires that commitments to any two different messages are indistinguishable to the adversary, even given knowledge of MSK (which is useful for forward security). The binding property states that no adversary, given only knowledge of PK and oracle access to $\text{Extract}(PK; \cdot; MSK)$, can produce a commitment which opens two different ways under identity ID without first querying $\text{Extract}(PK; ID; MSK)$. Finally, the equivocability property guarantees that the output of **Eqv** be indistinguishable from truly random coins, even to an adversary who knows MSK (again, for forward security reasons). We give a general construction of IBTCs in Appendix 5.2.2, but mention that they can be built from one-way functions (although more efficient number-theoretic constructs are possible as well).

Security of Identity-based Trapdoor Commitments. Identity-based Trapdoor Commitment schemes must satisfy the following security requirements, for any PPT adversary \mathcal{A} (in all the experiments below, 1^λ is an implicit input to the adversary, PK is an implicit input to *all* algorithms, and $(PK, MSK) \leftarrow \text{Setup}(1^\lambda)$):

- **Hiding** - For any PPT algorithm \mathcal{A} , any identity ID , and any two messages m_0 and m_1 ,

$$\left| \Pr[\mathcal{A}(MSK, ID, c) = 1 \mid (c, d) \leftarrow \text{Com}(ID; m_0)] - \Pr[\mathcal{A}(MSK, ID, c) = 1 \mid (c, d) \leftarrow \text{Com}(ID; m_1)] \right| \leq \text{negl}(\lambda)$$

- **Binding** - For any PPT algorithm \mathcal{A} given oracle access to $\text{Extract}(\cdot; MSK)$, for any identity ID not queried to the Extract oracle,

$$\Pr[\perp \neq \text{Open}(ID; c, d) \neq \text{Open}(ID; c, d') \neq \perp \mid (ID, c, d, d') \leftarrow \mathcal{A}^{\text{Extract}(\cdot; MSK)}] \leq \text{negl}(\lambda)$$

- **Equivocability** - For any PPT algorithm \mathcal{A} , any identity ID , and any message m , $|\delta' - \delta| \leq \text{negl}(\lambda)$ where

$$\delta' = \Pr \left[\mathcal{A}(MSK, ID, s', m) = 1 \mid \begin{array}{l} SK_{ID} \leftarrow \text{Extract}(ID; MSK), \\ (c, \alpha) \leftarrow \text{ECom}(ID; SK_{ID}), \\ s' \leftarrow \text{Eqv}(ID; SK_{ID}, c, \alpha, m) \end{array} \right]$$

and

$$\delta = \Pr[\mathcal{A}(MSK, ID, s, m) = 1 \mid s \leftarrow \mathcal{S}]$$

(Intuitively, in the experiment of δ' the adversary sees random coins s' that were used to equivocate a pre-existing commitment c so that $(c, d) \leftarrow \text{Com}(s'; PK; ID; m)$, whereas δ is the probability when the adversary sees truly random coins s , which imply an actual fresh commitment to m instead.)

Constructions of Identity-based Trapdoor Commitments. The following theorem summarizes the results of our IBTC construction technique:

Theorem 5.1. *There exists an efficient construction of an IBTC from any signature scheme with an “augmented Σ -protocol”. In particular, such signature schemes exist if one-way functions exist, and can be efficiently constructed under the Strong RSA assumption.*

The proof follows directly from the details of the construction, which we now outline.

5.2.1 Augmented Σ -Protocols

Our approach is based on the technique from [22] for constructing commitment schemes from “ Σ -protocols”. In particular, the basic tool we use to construct IBTCs is a modified form of standard Σ -protocols (see [32, 20]) that we call augmented Σ -protocols. Intuitively, Σ -protocols are three move protocols for proving some relation in zero knowledge. The augmented definition adds a “reverse state construction” property that enables the commitment schemes we construct to tolerate adaptive adversaries (who are able to learn the internal state of corrupted parties). We

do this by constructing “fake” state information for honest runs of the Σ -protocol (which require the prover to know the witness), in order to make them appear as if they were instead output by the zero-knowledge simulator (which does not require knowledge of the witness). Augmented Σ -protocols are closely related to the “non-erasure” Σ -protocols of [20], but require a slightly different state construction property (one that is roughly the “reverse” of the corresponding property in [20]).

Definition 4. Let $R = \{(x, w)\}$ be an efficiently testable binary relation, such that $|w| \leq \text{poly}(|x|)$ for all $(x, w) \in R$. Consider a three move protocol run between a prover P , with input $(x, w) \in R$, and a verifier V with input x , executed as follows. P chooses a random string r_a , computes $a \leftarrow A(x, w, r_a)$, and sends a to V . V then chooses a random string e (the “challenge”), and sends it to P . Finally, P responds with $z \leftarrow Z(x, w, r_a, e)$. The verifier V then computes and returns a bit $b = B(x, a, e, z)$. We require that A , Z , and B be poly-time algorithms, and that $|e| \leq \text{poly}(|x|)$. Such a protocol is called an Augmented Σ -Protocol if it satisfies the following properties with all but negligible probability:

- **Completeness** - If $(x, w) \in R$ then the verifier outputs $b = 1$.
- **Special HVZK** - There exists a PPT algorithm Sim such that the following property holds for all PPT distinguishers D , and for all challenges e , for any $(x, w) \in R$:

$$\Pr_{r_a}[D(x, w, a, e, z) = 1 \mid a \leftarrow A(x, w, r_a), z \leftarrow (x, w, r_a, e)] - \Pr_{r_s}[D(x, w, a, e, z) = 1 \mid (a, z) \leftarrow \text{Sim}(x, e, r_s)] \leq \text{negl}(|x|)$$

Intuitively, this says that for any a priori fixed challenge e , it is possible to produce a protocol transcript computationally indistinguishable from an actual run with the prover (who knows w), even without knowledge of w . Furthermore, we require that the indistinguishability holds even if the distinguisher knows the witness w . (This additional requirement is slightly stronger than the usual HVZK property.)

- **Reverse State Construction** - There exists a PPT algorithm RSC , which given an input tuple (x, w, r_a, e) for any $(x, w) \in R$, and any choice of challenge e , outputs random coins r'_s such that $(a', z') \leftarrow \text{Sim}(x, e, r'_s)$ satisfies $a' = A(x, w, r_a)$ and $z' = Z(x, w, r_a, e)$. Furthermore, for all PPT distinguishers D , and any challenge e , the following indistinguishability property holds:

$$\Pr_{r_s}[D(x, w, e, r_s) = 1] - \Pr_{r_a}[D(x, w, e, r'_s) = 1 \mid r'_s \leftarrow \text{RSC}(x, w, r_a, e)] \leq \text{negl}(|x|)$$

Intuitively, this property states that given the random coins of the prover after a standard run of the Σ -protocol, it is possible to find appropriate random coins for the simulator that cause it output the same transcript. Furthermore, even an adversary who knows the witness cannot determine whether those random coins were chosen according to this reconstruction procedure or not. It is easy to verify that this property actually implies the above Special HVZK property of Σ -protocols as well, but we state it separately only for conceptual clarity.

- **Special Soundness** - There exists a PPT algorithm Ext , which given an input tuple (x, a, e, z, e', z') such that $e \neq e'$ and $B(x, a, e, z) = B(x, a, e', z') = 1$, outputs w such that $(x, w) \in R$.

5.2.2 An IBTC from Signature Schemes with Augmented Σ -Protocols

Let $\Phi = (\text{Gen}, \text{Sig}, \text{Ver})$ denote any signature scheme that is existentially unforgeable against chosen message attack (*i.e.* it is UF-CMA secure). Define a relation $R^\Phi(x, w)$ such that $(x, w) \in R^\Phi$ if either 1) $x = \langle VK, m \rangle$ and $w = \sigma$ such that $\text{Ver}(VK; m, \sigma) = \text{accept}$; or 2) $w = r_g$ such that $(VK, \cdot) = \text{Gen}(r_g; 1^\lambda)$ (*i.e.* w contains the random coins used by the Gen algorithm in producing VK).⁸ We say that Φ has an Augmented Σ -Protocol if there is an Augmented Σ -Protocol for the relation R^Φ . Given such a signature scheme, we can construct an Identity-based Trapdoor Commitment scheme as follows:

- **Setup(1^λ):** Compute $(VK, SK) \leftarrow \text{Gen}(r_g; 1^\lambda)$, where r_g denotes the random coins used by the Gen algorithm. Return the pair $(PK = VK, MSK = \langle r_g, SK \rangle)$.
- **Extract($PK; ID; MSK$):** Parse $MSK = \langle r_g, SK \rangle$. Compute $\sigma_{ID} = \text{Sig}(SK; ID)$. Return $SK_{ID} = \sigma_{ID}$.
- **Com($s; PK; ID; m$):** Compute $(a, z) \leftarrow \text{Sim}(x = \langle PK, ID \rangle, e = m, r_s = s)$, where Sim is the Σ -protocol simulator for R^Φ . Return the pair $(c = a, d = \langle m, z \rangle)$.
- **Open($PK; ID; c, d$):** Parse $d = \langle m, z \rangle$. If $B(x = \langle PK, ID \rangle, a = c, e = m, z) = 1$, return m . Otherwise, return \perp . B is algorithm run by the verifier in the Σ -protocol for R^Φ .
- **ECom($PK; ID; SK_{ID}$):** Choose random coins r_a and compute $a = A(x = \langle PK, ID \rangle, w = SK_{ID}, r_a)$. Return the pair $(c = a, \alpha = r_a)$.
- **Eqv($PK; ID; SK_{ID}, c, \alpha, m$):** Compute $r_s = \text{RSC}(x = \langle PK, ID \rangle, w = SK_{ID}, r_a = \alpha, e = m)$. Return $s = r_s$.

Intuitively, the message m is used as the “challenge” flow in the Zero-Knowledge simulator for the Σ -protocol. The resulting prover’s first flow is used as a commitment, and the prover’s response flow is used for the decommitment. Equivocation is achieved by using knowledge of the witness (*i.e.* the equivocation trapdoor) to “honestly” conduct the ZK proof (instead of simulating) so that the prover can respond to any “challenge”, even after the first flow is sent as the commitment.

Theorem 5.2. *The construction described above yields a secure IBTC scheme.*

Proof. It is easy to verify the correctness of the above IBTC implementation. We now proceed to prove the three security properties.

- **Hiding.** To prove the hiding property, it suffices to observe that commitments are simulated Σ -protocol first round flows. By the Special HVZK property, these flows are indistinguishable from the output of $A(x = \langle PK, ID \rangle, w = SK_{ID}, r_a)$, which is entirely independent of the choice of message. Furthermore, this indistinguishability holds even with respect to an adversary given w (which can contain the random coins r_g used by the Gen algorithm, so there is sufficient information available to reproduce MSK needed for the reduction).

⁸We allow the randomness used by the key generation algorithm, r_g , to be used as a witness in order to provide the “forward security” property needed for our IBTC to provide “strong” full simulatability.

- **Binding.** Suppose there is an adversary \mathcal{A} breaking the binding property of the commitment scheme. We construct an adversary that forges signatures under Φ , proceeding as follows:
 1. Let $PK = VK$, for the signature scheme. Run $\mathcal{A}^{\text{Extract}(PK; \cdot; MSK)}(PK)$, simulating responses from the oracle by querying the signature oracle $\text{Sig}(SK; \cdot)$ (in the unforgeability game).
 2. Wait until \mathcal{A} outputs a tuple (ID, c, d, d') breaking the binding property
 3. Parse $c = a, d = \langle m, z \rangle, d' = \langle m', z' \rangle$. Note that here we will have $m \neq m'$.
 4. Compute $\sigma = \text{Ext}(x = \langle PK, ID \rangle, a, e = m, z, e' = m', z')$. By construction, we will have that $\text{Ver}(PK; ID, \sigma)$ will accept.
 5. Return a forged message/signature pair (ID, σ) . Observe that ID was never queried to the Extract oracle by \mathcal{A} , and thus was never queried to the Sig oracle.

Thus, if the signature scheme is unforgeable, binding property holds.

- **Equivocability.** Equivocability of commitments follows immediately from the Reverse State Construction property of Σ -protocols. Clearly, any adversary capable of distinguishing the output of Eqv from random coins, when given access to MSK , can also be used to distinguish the output of RSC when the witness provided is r_g .

□

5.2.3 Signature Schemes with Augmented Σ -Protocols

To complete the construction of IBTCs, it remains to construct a signature scheme with an augmented Σ -protocol for the knowledge of the signature. First, we observe that every NP -relation is known to have such a Σ -protocol if one-way functions exist [23, 27, 3]. Specifically, the protocol of [3] (where the prover commits to a permutation of a graph with a Hamiltonian cycle, and is challenged to reveal either a cycle or the permutation) is easily shown to support the requirements of augmented Σ -protocols when using pseudo-random commitments. In particular, the reverse state construction property can be achieved by simply producing random coins corresponding to the graph opened by the simulator, along with coins yielding the same random commitment values used by all the unopened commitments to edges in the graph (relying on the pseudo-randomness of the commitments).

Since signature schemes can also be constructed from one-way functions, we immediately obtain a generic construction of IBTCs based on one-way functions. We also notice that we can have more efficient constructions if we use certain signature schemes based on specific number-theoretic assumptions. For example, we can use any “signature scheme with efficient protocols”, such as the one of [15] based on strong RSA.

5.3 Dense OT-PRC Secure Encryption

The commitment protocol of [18] (which uses a common reference string) requires the use of a CCA secure public key encryption scheme with Pseudo-Random Ciphertexts (PRC). The CCA security requirement arises due to the fixed nature of the global public key, which is reused during every

run of the protocol. Our protocol, on the other hand, will not make use of any fixed public keys for encryption. Instead, we will be using a coin-flipping protocol to choose a fresh public key for each run of our commitment protocol (this is discussed in more detail below). One advantage of doing this is that we will require only One-Time (OT) secure encryption with PRC, since each key is used only once. However, there is also a disadvantage: the public key is chosen as the result of a fair coin-flipping protocol (which should be uniformly random), so the encryption scheme must have “dense” public keys. Informally, this means we require public keys to be computationally random bit strings. Fortunately, schemes satisfying these requirements exist under widely used computational assumptions, such as the DDH assumption (in fact, standard El-Gamal encryption suffices). The formal definition of security for Dense OT-PRC encryption provided below has the flavor of “left-or-right” security, which is most convenient for the proof of security of our protocol.

Definition 5 (Dense OT-PRC Encryption). *A public key encryption scheme $OTPRC = (G, E, D)$, satisfying the standard correctness properties for public key encryption, is said to be Dense OT-PRC secure if the following holds for all PPT adversaries \mathcal{A} (for convenience, the security parameter λ is set to match the length of public keys):*

$$\Pr[A^{LR(\cdot,0)}(1^\lambda) = 1] - \Pr[A^{LR(\cdot,1)}(1^\lambda) = 1] \leq \text{negl}(\lambda)$$

where the answer to a query of the oracle $LR(m, b)$ is computed by obtaining $(K, K^{-1}) \leftarrow G(1^\lambda)$ and returning the pair $\langle K, E_K(m) \rangle$ if $b = 0$, or returning the uniformly random pair $\langle U, R \rangle$ if $b = 1$ (where U is chosen from $\{0, 1\}^\lambda$ and R from $\{0, 1\}^{|E_K(m)|}$). Note that fresh keys are computed on each query to the oracle.

5.4 Details and Design of Protocol UAIBC

A full description of the protocol UAIBC in the $\bar{\mathcal{G}}_{acrs}$ (Augmented CRS) model is shown in Figure 8 below.

Intuitively, the final flow of the commit phase of the UAIBC protocol is very similar to the UAHC protocol of [18] and the CLOS-KR protocol of [5]. The difference in the structure of the last flow we send is our use of a single ciphertext, rather than two ciphertexts as in [18]. The only purpose of this minor change is to further simplify the presentation of the protocol and the proof, and indeed it would seem that the same change can be safely made to the UAHC and CLOS-KR protocols.

The novelty of protocol UAIBC is its use of a coin-flipping protocol to choose the public key for the encryption scheme (used for e), rather than using a globally fixed key as in [18], or public keys belonging to the individual parties as in [5]. The net result of this coin-flipping protocol is that no party (trusted or otherwise) should ever be in possession of the decryption key, unless perhaps some “cheating” occurred during the coin-flipping process (as we will discuss below).

Of course, the use of this coin-flipping protocol makes the commitment phase of the protocol interactive (whereas in [18] it was not). We remark that such interactivity seems to be of fundamental importance when achieving full simulatability (*i.e.* true GUC security) in the Augmented CRS model. In particular, interaction allows the simulator to leverage its control over the simulated random tapes of honest parties, which is the only real means of “cheating” that the simulator has when simulating honest parties. Without allowing such an ability to “cheat” for the simulator, the impossibility result for fully simulatable commitments in the CRS model would carry over to the ACRS model as well.

Protocol UAIBC

Let (G, E, D) be a Dense OT-PRC secure encryption scheme. We denote the key-space of the dense encryption scheme by $\mathcal{K} = \{0, 1\}^\lambda$. Then Protocol UAIBC proceeds as follows, with party P_i committing a bit b to party P_j in the $\bar{\mathcal{G}}_{acrs}^{\text{Setup, Extract}}$ -hybrid model.

Common Reference String: All parties are initialized with the common reference string produced by $\bar{\mathcal{G}}_{acrs}^{\text{Setup, Extract}}$ (the public key for the *IBTC* scheme produced by **Setup**, which is an implicit parameter to the **Com** and **Open** algorithms). In particular, we note that $\bar{\mathcal{G}}_{acrs}^{\text{Setup, Extract}}$ is a shared subroutine of Protocol UAIBC.

Commit Phase:

1. On input $(\text{commit}, \text{sid}, P_i, P_j, b)$ where $b \in \{0, 1\}$, party P_i sends $(\text{com}_0, \text{sid}, P_i, P_j)$ to P_j . It then waits to receive a message of the form $(\text{com}_1, \text{sid}, P_i, P_j, c_k)$ from P_j .
2. P_j receives $(\text{com}_0, \text{sid}, P_i, P_j)$ and records it, ignoring any later com_0 messages from P_i with the same sid . P_j chooses a random $k_1 \in \mathcal{K}$, then computes and records $(c_k, d_k) = \text{Com}(P_i; k_1)$. P_j sends $(\text{com}_1, \text{sid}, P_i, P_j, c_k)$ to P_i and waits to receive the message of the form $(\text{com}_2, \text{sid}, P_i, P_j, k_2)$ from P_i .
3. P_i receives and records $(\text{com}_2, \text{sid}, P_i, P_j, k_2)$, ignoring any later com_2 messages from P_i with the same sid . P_i then chooses a random $k_2 \in \mathcal{K}$, sends the message $(\text{com}_3, \text{sid}, P_i, P_j, k_2)$ to P_j , and waits to receive of a message of the form $(\text{com}_3, \text{sid}, P_i, P_j, d_k)$ from P_j .
4. P_j receives $(\text{com}_2, \text{sid}, P_i, P_j, k_2)$ and records it, ignoring any later com_2 messages from P_i with the same sid . P_j computes and stores $K = k_1 \oplus k_2$, and then sends $(\text{com}_3, \text{sid}, P_i, P_j, d_k)$ to P_i and waits to receive a message of the form $(\text{com}_4, \text{sid}, P_i, P_j, c, e)$ from P_i .
5. P_i receives and records $(\text{com}_3, \text{sid}, P_i, P_j, d_k)$ from P_j , ignoring any later com_3 messages from P_i with the same sid . P_i then computes and stores $k'_1 = \text{Open}(P_i; c_k, d_k)$. If **Open** fails, then P_i ignores the message, otherwise P_i sets $K = k'_1 \oplus k_2$, and then computes and stores $(c, d) = \text{Com}(P_j; b)$. Additionally, if $b = 0$, P_i chooses random coins r and then computes and stores $e = E_K(r; d)$ along with r ; otherwise P_i chooses e at random. P_i then sends $(\text{com}_4, \text{sid}, P_i, P_j, c, e)$ to P_j .
6. P_j receives $(\text{com}_4, \text{sid}, P_i, P_j, c, e)$ from P_i and records it, ignoring any later com_4 messages from P_i with the same sid . P_j then outputs $(\text{receipt}, \text{sid}, P_i, P_j)$.

Reveal Phase:

1. On input $(\text{reveal}, \text{sid})$ party P_i retrieves the necessary records and, if $b = 0$, sends $(\text{rev}, \text{sid}, P_i, P_j, 0, d, r)$ to P_j ; otherwise, P_i sends $(\text{rev}, \text{sid}, P_i, P_j, 1, d)$ to P_j .
- 2a. When receiving a message of the form $(\text{rev}, \text{sid}, P_i, P_j, 0, d, r)$, P_j records it, ignoring all subsequent messages from P_i with the same sid . P_j then retrieves the values of K , c , and e corresponding to sid from its records and computes $e' = E_K(r; d)$. If $e' = e$, and $\text{Open}(P_j; c, d) = 0$ then P_j outputs $(\text{reveal}, \text{sid}, P_i, P_j, 0)$. Otherwise, it ignores the message.
- 2b. When receiving a message of the form $(\text{rev}, \text{sid}, P_i, P_j, 1, d)$, P_j records it, ignoring all subsequent messages from P_i with the same sid . P_j then retrieves the values of c corresponding to sid from its records and computes checks that $\text{Open}(P_j; c, d) = 1$. If so, then P_j outputs $(\text{reveal}, \text{sid}, P_i, P_j, 1)$. Otherwise, it ignores the message.

Figure 8: Protocol UAIBC for realizing \mathcal{F}_{com} in the $\bar{\mathcal{G}}_{acrs}$ -Externalized UC setting

Simulation of our protocol is slightly involved. On a high level, as with all UC-secure realizations of \mathcal{F}_{com} , the simulator must be able to extract the actual committed values being sent by corrupt parties during the commit phase, while simultaneously being capable of equivocating commitments that are sent by honest parties (for which the simulator must generate the protocol flows). On the surface, these properties seem to conflict, since if a specific value can be extracted from a flow of the commitment protocol, then the flow must be binding. Yet, the simulator must also be able to equivocate flows. This conflict becomes even more striking in our model, where the adversary is allowed to learn all the same trapdoor information as the simulator. Indeed, that restriction is precisely what causes the UAHC protocol to fail in our setting. To further complicate matters, it would seem that if the simulator has the power to extract committed values and to equivocate commitments, an equally powerful real-world adversary should also have these capabilities. Fortunately, there is one crucial advantage that the simulator is allowed to have that enables us to overcome these conflicts: the simulator is allowed to choose the random coins used to generate the protocol flows of honest parties, whereas the real-world adversary has no such control (although it may learn the random coins upon later corruption of the honest party). The coin-flipping technique is a method for leveraging this advantage.

The coin-flipping protocol executed in Steps 1-4 of the UAIBC commitment protocol is designed so that the simulator can program the outcome of the coin-flip whenever party P_i is corrupt. By using the P_i 's IBTC key, SK_{P_i} , to equivocate the commitment sent in Step 2, the simulator can arrange the public key K to be any string of its choosing. Of course, the simulator will choose a public key K for which it knows the corresponding secret key, K^{-1} . Thus, if party P_i is corrupt, the simulator is able to decrypt the ciphertext sent in Step 5, extracting the committed value.

To equivocate commitments sent to a corrupt party P_j , the simulator uses the IBTC key belonging to P_j , SK_{P_j} , in order to generate an equivocable commitment to be sent in the final flow (Step 5). The ciphertext sent contains a legitimate opening to 0, but will later be passed off as a random ciphertext in the event that the simulator must open to 1. While such an equivocation could be detected by someone with knowledge of K^{-1} , in this instance, no one (not even the simulator) can have such knowledge, as the coin-flipping process will be fair.

Proving that the simulation described above is indeed indistinguishable from the real-world interaction requires the use of a rewinding technique. We stress that the UC simulation itself does not employ any rewinding (which is of critical importance, since a UC simulator may not rewind the environment). However, the use of a rewinding technique is required whenever we must “program” the coin-flipping results in the case where the adversary corrupts party P_j . In particular, this scenario is encountered only in the reduction to the security of the encryption scheme used for one of the simulation indistinguishability hybrid arguments. In order to show that the encryption can be broken if the hybrid experiments can be distinguished, we must arrange for the encryption key being attacked by the reduction to appear in the outcome of the coin-flipping (even when P_j is corrupted).

In summary, protocol UAIBC introduces a technique for transforming trapdoor commitments (which are merely equivocable) to full-fledged (adaptive *and* forward secure!) UC commitments (which must be both equivocable and extractable) by using a simulatable coin-flipping protocol. In particular, the simulatable coin-flipping protocol makes use of both rewinding and trapdoors to achieve simulatability. (We employ only the trapdoor based simulation technique when constructing the UC simulator itself, while relying on the ability to rewind the coin-flipping protocol *only for the*

proof of the simulation’s indistinguishability.) Our general approach to constructing adaptively UC secure commitments from standard trapdoor commitments is of independent interest, and indeed, the problem was implicit in many prior works (*e.g.* [18, 16, 7]) which either resort to impractical techniques (such as per-session CRS) or are forced to settle for static (non-adaptive) security.

5.5 Security Proof for Protocol UAIBC

We now prove that protocol UAIBC is a GUC-secure realization of \mathcal{F}_{com} in the $\bar{\mathcal{G}}_{acrs}$ shared hybrid model.

Proof of Theorem 4.2. We prove the theorem by showing that protocol UAIBC is a GUC-secure realization of \mathcal{F}_{com} . We will describe the technique for simulating protocol flows in UAIBC in the ideal-world, and give a proof that the simulation in the ideal-world setting is indistinguishable from a real-world execution of UAIBC, even if the adversary is allowed to corrupt the trusted party implementing $\bar{\mathcal{G}}_{acrs}$ at the end of the game. Recall that we need only prove that UAIBC will $\bar{\mathcal{G}}_{acrs}$ -EUC-emulate \mathcal{F}_{com} , and thus we will be proving with respect to a $\bar{\mathcal{G}}_{acrs}$ -externally constrained environment \mathcal{Z} . To model this, we may imagine that \mathcal{Z} is provided with SK_{P_a} , for any corrupt party P_a , at the moment of corruption. (In reductions to the security of the IBTC, we make an oracle query to obtain the key SK_{P_a} , which, as can be seen below, will never correspond to the key under attack by the reduction.)

Initialization - All parties are initialized with a copy of the common reference string PK published by $\bar{\mathcal{G}}_{acrs}^{\text{Setup,Extract}}$ during its honestly executed global initialization step. That is, the simulation we describe below merely expects the initialization step to be completed prior to the start of the simulation (no special setup is required on behalf of the simulator itself).

Simulating Communication with \mathcal{Z} - \mathcal{S} simply forwards communications between \mathcal{A} and \mathcal{Z} .

Simulating the commit phase for honest parties (Strategy 1) - Since we are in the secure channels model, the simulator need only send null messages of appropriate length for each of the messages passed in UAIBC. Nothing more need be done unless one of the parties is corrupted at some later time. If the sender is later corrupted, the simulator receives the sender’s input and can construct internal state for the sender representing an honestly generated transcript. If the recipient is later corrupted (prior to the reveal phase, which would again provide the simulator with the correct input) then the simulator must follow the strategy we now describe for the case of a recipient corrupted prior to the sender.

Simulating the commit and reveal phases for corrupt recipients (Strategy 2) - If the recipient is corrupted at any point during the commit phase while the sender is still honest, the simulator conducts the following strategy. We note that, once again, we depend critically on the secure channels model to allow the simulator to choose the content of the prior transcript only *after* corrupting the recipient in the ideal model. Since only the recipient has been corrupted, the simulator must be able to complete the commit phase of the protocol on behalf of the sender without actually knowing the committed bit b (which \mathcal{F}_{com} will not disclose until the reveal phase is initiated). Thus, the simulator needs to be able equivocate the commitment so that it can be opened to the proper value b in the subsequent reveal phase.

Before generating any of the protocol flows, \mathcal{S} issues a `retrieve` request to $\bar{\mathcal{G}}_{acrs}^{\text{Setup,Extract}}$ on behalf of the corrupt P_j in order to obtain SK_{P_j} . All flows will be honestly generated except the final message sent by P_i in Step 5 of the commit phase of the protocol. \mathcal{S} computes $(\hat{c}, \alpha) = \text{ECom}(P_j; SK_{P_j})$ and $s_{\hat{b}} = \text{Eqv}(P_j; SK_{P_j}; \hat{c}, \alpha, \hat{b})$, $(\hat{c}, d_{\hat{b}}) = \text{Com}(s; P_j; \hat{b})$ for $\hat{b} = 0, 1$ and stores the results. Instead of the honest flow, \mathcal{S} sends $(\text{com}_4, \text{sid}, P_i, P_j, \hat{c}, \hat{e})$ where \hat{e} is the encryption of d_0 (computed exactly as though committing to $b = 0$ in Step 5).

When performing the reveal phase, \mathcal{S} can simply open to $b = 0$ using the decommitment d_0 honestly (including opening \hat{e} correctly). If \mathcal{S} must open to $b = 1$ it can use the decommitment d_1 , and by the pseudo-random property of the encryption scheme, it can “pretend” that \hat{e} was chosen at random. If the sender is later corrupted and \mathcal{S} must generate internal state for P_i , it can use s_b to show how (c, d_b) was generated (of course b can be clearly seen from P_i ’s input, upon the initial corruption).

Simulating the commit and reveal phases for corrupt senders (Strategy 3) - If the sender is corrupted while the recipient is honest during the commit phase, the simulator will need to learn the committed bit b from the sender in order to correctly provide the corresponding commit phase input to \mathcal{F}_{com} . Once again, we note that the simulator need not generate any actual protocol flows until the actual time of corruption, so the following strategy may be employed irrespective of the particular step in the protocol of the commit phase at which P_i is corrupted. Upon the initial corruption of P_i , \mathcal{S} will issue a `retrieve` request to $\bar{\mathcal{G}}_{acrs}^{\text{Setup,Extract}}$ on P_i ’s behalf in order to retrieve SK_{P_i} . The simulation strategy will replace the flows sent by P_j in Steps 2 and 4 with specially “rigged” flows. \mathcal{S} first generates and stores a valid key-pair for the dense encryption scheme $(\bar{K}, \bar{K}^{-1}) = G(1^\lambda)$. For Step 2, \mathcal{S} computes and stores $(\hat{c}_k, \alpha) = \text{ECom}(P_i; SK_{P_i})$, sending \hat{c}_k in place of the honestly computed c_k (on behalf of the honest party P_j). In Step 4, \mathcal{S} computes and stores $\hat{k}_1 = \bar{K} \oplus k_2$ and $\hat{s} = \text{Eqv}(P_i; SK_{P_i}; \hat{k}_1)$. \mathcal{S} replaces the legitimate decommitment d_k that would normally be sent in Step 4 with \hat{d}_k where $(\hat{c}_k, \hat{d}_k) = \text{Com}(\hat{s}; P_i; \hat{k}_1)$. This procedure ensures that \mathcal{S} knows the decryption key for the ciphertext e sent by P_i in Step 5, and can thus decrypt e if $b = 0$ and it was legitimately formed. If \mathcal{S} is able to decrypt e to obtain a valid d such that $\text{Open}(c, d) = 0$, then \mathcal{S} proceeds by invoking \mathcal{F}_{com} as if P_i had committed to 0, otherwise it invokes it with a commitment to 1 (since P_i cannot possibly produce a valid opening of the commitment to 0 in this case). In the event that P_j is corrupted by the adversary after using the equivocate (\hat{c}_k, \hat{d}_k) described above, the simulator will use \hat{s} to provide internal state for P_j consistent with that commitment.

Notice that in this scenario, the simulator will not need to send any message during the reveal phase, since the sender is corrupted and is the only party sending messages during a reveal operation. The simulation will only fail (and halt) if a valid reveal phase message is sent from P_i (who is corrupt, and controlled by \mathcal{A}) which opens to a different bit b than the simulator chose when invoking \mathcal{F}_{com} at the end of the commit phase.

Message delivery - \mathcal{S} will merely deliver messages from \mathcal{F}_{com} whenever \mathcal{A} delivers the corresponding protocol messages in the simulated UAIBC interaction, in the obvious manner.

Given the above simulation strategies, we must prove that the environment \mathcal{Z} ’s interactions with \mathcal{S} will be indistinguishable from \mathcal{Z} ’s interactions with \mathcal{A} in the real-world, even if \mathcal{A} is allowed

to corrupt the trusted party $\mathsf{T}_{\bar{\mathcal{G}}_{acrs}}$ at the end of the experiment. To show this, we consider the following hybrid experiments.

I_0 - **Real-world interaction.** Protocol UAIBC running in the “real-world” (in this case, the $\bar{\mathcal{G}}_{acrs}$ -Relativized setting), interacting with the real-world adversary \mathcal{A} .

I_1 - **Employing the commitment part of Strategy 2.** The interaction proceeds exactly as in the real-world, except that wherever Step 5 of the protocol is executed with a corrupt receiver P_j , the honest sender P_i computes $(\hat{c}, \alpha) = \mathsf{ECom}(P_j; SK_{P_j})$ (for now, we will simply imagine that that P_i is somehow provided with SK_{P_j}). P_i then obtains $s = \mathsf{Eqv}(P_j; SK_{P_j}; \hat{c}, \alpha, b)$, and a corresponding decommitment d is computed as $(\hat{c}, d) = \mathsf{Com}(s; P_j; b)$. The remainder of the protocol is then conducted as usual. In the event that P_i is later corrupted, its internal state is “fixed” (in the obvious way) to make it look as though P_i directly computed $(\hat{c}, d) = \mathsf{Com}(s; P_j; b)$ without first applying the equivocation algorithm.

Lemma 5.3. I_1 is computationally indistinguishable from I_0 .

Proof. The proof is by reduction to the equivocability property of $IBTC$ s, since the only difference from I_0 is the use of an equivocable commitment. We observe that if there is an adversary \mathcal{A} such that \mathcal{Z} can distinguish interactions in I_0 from I_1 , there is a (simple) reduction which breaks the equivocability property of the $IBTC$. This indistinguishability holds even for adversaries in the strong fully simulatable setting, since the reduction is given MSK (containing the random coins used by Setup) as part of its input. Thus, it is easy for the reduction to properly simulate even the corruption of the trusted party. We omit the trivial details of the reduction. \square

I_2 - **Employing only Strategy 2.** This interaction is the same as I_1 , only P_i will perform Step 5 completely as described in Strategy 1. That is, in addition to the change made in I_1 , the only difference between I_2 and I_1 is the computation of the value of e . In the event that the honest party commits a bit $b = 1$, the value of e now contains $E_K(r; d_0)$, whereas it would have been random in I_1 .

Lemma 5.4. I_2 is computationally indistinguishable from I_1 .

Proof. The proof is by reduction to the pseudo-random property of ciphertexts from E . Unfortunately, it is not obvious how to build a reduction attacking the security of a particular public key K^* , as we must do in order to achieve the reduction. In fact, we must use a “rewinding” technique in order to accomplish this. While it is critical that UC secure protocols be straight-line *simulatable* (*i.e.* they may not use rewinding techniques for simulation purposes, see [30] for details), we stress that here we are using the rewinding only in the proof of indistinguishability for the simulator. The simulator itself does not perform any rewinding.

Our reduction will make use of the Reset Lemma of [8]. Suppose there exists an environment \mathcal{Z} capable of distinguishing a run of the interaction in I_1 from that of I_2 with probability ϵ . We observe that I_1 and I_2 are identically distributed, except in the case where an honest party attempts to commit to $b = 1$, and the commitment phase of the protocol runs to completion (*i.e.* the final flow of the commit phase was sent by the honest party). Thus, we know that

$b = 1$ is the input to the commitment protocol with probability at least ϵ (since this is the only way for \mathcal{Z} to gain an advantage). Our reduction will attempt to distinguish distributions of the form $\langle K^*, E_{K^*}(r; d_0) \rangle$ from $\langle K^*, R \rangle$ (where K^* is a uniformly distributed public key and R is random), breaking the pseudo-random ciphertext property of the encryption scheme, as follows:

- Step A: Wait until the honest party’s commitment to $b = 1$ is simulated to completion. (This will occur when the receiving party has been corrupted at some point during the simulation. Without loss of generality, we will assume this corruption occurs prior to the initiation of the commitment protocol. In the event that the corruption occurred later, the reduction is even further simplified, since the simulator need not rewind the adversary in order to accomplish the goal of Step B.) Record the commitment/decommitment pair (c_k, d_k) sent in steps 2 and 4 of the UAIBC protocol.
- Step B: Rewind the adversary \mathcal{A} , all parties, and the environment \mathcal{Z} to the point just prior to step 3 of the UAIBC protocol. Obtain a challenge distribution $\langle K^*, e^* \rangle$ from the LR oracle with input d_0 (see Definition 5), so that e^* will be either randomly distributed, or an encryption of d_0 under K^* (*i.e.* this is the distribution the reduction is required to distinguish). Replace the randomly chosen k_2 to be sent by the honest party with $k_2^* = K^* \oplus \text{Open}(c_k, d_k)$, and resume the simulation. We observe that, unless \mathcal{A} finds an alternative opening of c_k (breaking the binding property of the IBTC), if the protocol once again completes successfully, we will have that the key K used in the final flow of the commit phase is actually K^* . In step 5 of protocol UAIBC, set $e = e^*$ (which mimics I_1 if e^* is chosen from the random distribution, and I_2 otherwise). It remains only to argue that, in spite of the rewinding (which substituted the flow in step 3 of UAIBC), the commitment phase still completes successfully with non-negligible probability. Suppose that the a priori probability that a successful commitment phase run of the form specified in Step A occurs is ϵ . Following the same analysis of the Reset Lemma in [8]⁹, we obtain that the probability of a successful reset experiment is at least $\epsilon^2 - \epsilon/|\mathcal{K}| = \epsilon^2 - \epsilon/2^\lambda$, which is clearly non-negligible whenever ϵ is non-negligible.
- Step C: Obtain the distinguishing output from \mathcal{Z} after running to completion. If \mathcal{Z} selects I_1 , the reduction assumes the input distribution was drawn from (K^*, R) , otherwise, it assumes the distribution was $(K^*, E_{K^*}(r; d_0))$. Clearly, if \mathcal{Z} succeeds in distinguishing correctly, then so does our reduction. Furthermore, \mathcal{Z} ’s probability of success remains non-negligible, even after the rewinding of Step B. Thus, we can distinguish ciphertexts from random if there exists a \mathcal{Z} that distinguishes I_1 from I_2 , contradicting the pseudo-random ciphertext security property of the encryption scheme.

Once again, we observe that providing the adversary with MSK at the end of the game does not help the adversary to distinguish ciphertexts, since it is too late to use it to equivocate any of the commitments, and thus the adversary cannot “rig” any public keys. \square

I_3 - Adding Strategy 3. This interaction is the same as I_2 only now P_j also employs Strategy 2. We first note that it is not a problem that the simulator is revealing commitments to \hat{k}_1 instead

⁹The essence of the Reset Lemma is that, when fixing the random tapes of the (combined) adversary, if one random challenge caused the protocol to succeed with non-negligible probability, the probability that a different random challenge (chosen from a sufficiently large space) will also succeed after rewinding will be non-negligible.

of k_1 since the distributions are indistinguishable by the “dense” public key property of the encryption scheme. The only remaining difference is the use of an equivocable commitment, and thus we prove indistinguishability of I_3 and I_2 using the same technique as Lemma 5.3.

I_4 - **Adding Strategy 1.** This interaction is the same as I_3 , only we now employ Strategy 1 as well. This is, in fact, just a conceptual change to I_3 , since Strategy 1 merely delays the actual computation of protocol flows until they are observable by \mathcal{A} . Indistinguishability follows immediately in the secure channels model.

I_5 - **Simulated interaction.** This is the same as I_5 unless the simulation fails and halts, which can only occur if a reveal phase successfully opens a commit phase to for the bit $b' \neq b$, where b is the bit the simulation invoked \mathcal{F}_{com} with after the commit phase. This can occur in one of two ways. 1) The simulator was unable to decrypt e to yield a valid d in Step 5, yet the reveal phase shows that e contains a correct encryption of a valid d . This would violate correctness property of the encryption scheme, so this case never occurs. 2) The simulator decrypted e , yielding a valid d such that $\text{Open}(c, d) = 0$, but the reveal phase showed a decommitment d' such that $\text{Open}(c, d') = 1$. This breaks the binding property of the $IBTC$, and a reduction to this property can be built in the obvious way (we observe that the binding property is broken at “runtime”, so the reduction will not need to simulate the corruption of the trusted party in the strong fully simulatable setting, which is critical since it will not know MSK). Thus I_5 must be indistinguishable from I_4 .

□

6 Acknowledgments

The authors would like to thank Philip MacKenzie and Silvio Micali for insightful observations, as well as various anonymous referees for helpful comments and suggestions.

References

- [1] G. Ateniese and B. de Medeiros. Identity-based Chameleon Hash and Applications. *Proc. of Financial Cryptography*, 2004. Available at <http://eprint.iacr.org/2003/167/>.
- [2] D. Beaver. Secure Multi-party Protocols and Zero-Knowledge Proof Systems Tolerating a Faulty Minority. in *J. Cryptology*, vol 4., pp. 75–122, 1991.
- [3] M. Blum. How to prove a theorem so no one else can claim it. In *Proc. of the International Congress of Mathematicians*, 1986.
- [4] B. Barak, R. Canetti, Y. Lindell, R. Pass and T. Rabin. Secure Computation Without Authentication. In *CRYPTO 2005*, Springer-Verlag (LNCS 3621), pages 361-377, 2005.
- [5] B. Barak, R. Canetti, J. Nielsen and R. Pass. Universally composable protocols with relaxed set-up assumptions. In *Proc. of FOCS*, 2004.
- [6] D. Boneh, and M. Franklin. Identity Based Encryption from the Weil Pairing. In *Proc. of Crypto*, 2001.
- [7] B. Barak and Y. Lindell. Strict Polynomial-time Simulation and Extraction. In *SIAM J. Comput.*, 33(4), pp. 783-818, 2004.

- [8] M. Bellare and A. Palacio. GQ and Schnorr Identification Schemes: Proofs of Security against Impersonation under Active and Concurrent Attacks. In *Proc. of Crypto*, Springer-Verlag (LNCS 2442), 2002.
- [9] B. Barak and A. Sahai, How To Play Almost Any Mental Game Over the Net - Concurrent Composition via Super-Polynomial Simulation. In *Proc. of FOCS*, 2005.
- [10] R. Canetti. Security and composition of multi-party cryptographic protocols. *Journal of Cryptology*, Vol. 13, No. 1, winter 2000.
- [11] R. Canetti. Universally Composable Security: A New paradigm for Cryptographic Protocols. In *Proc. of FOCS*, pages 136–145, 2001.
- [12] R. Canetti. Universally Composable Security: A New paradigm for Cryptographic Protocols. Cryptology ePrint Archive, Report 2000/067, **revised edition from Dec. 2005**. Available at: <http://eprint.iacr.org/2000/067>
- [13] R. Canetti. Universally Composable Signature, Certification, and Authentication. In *Proc. of CSFW*, p. 219, 2004.
- [14] Ronald Cramer, Ivan Damgard, Berry Schoenmakers. Proofs of Partial Knowledge and Simplified Design of Witness Hiding Protocols. In *Proc. of CRYPTO*, pp. 174–187, 1994.
- [15] J. Camenisch and A. Lysyanskaya. A signature scheme with efficient protocols. In *Conference on Security in Communication Networks (SCN)*, 2002.
- [16] R. Canetti and M. Fischlin. Universally Composable Commitments. In *Proc. of Crypto*, pages 19–40, 2001.
- [17] R. Canetti, E. Kushilevitz and Y. Lindell. On the Limitations of Universally Composable Two-Party Computation Without Set-Up Assumptions. In *Proc. of Eurocrypt*, Springer-Verlag (LNCS 2656), pp. 68–86, 2003.
- [18] R. Canetti, Y. Lindell, R. Ostrovsky and A. Sahai. Universally Composable Two-Party and Multi-Party Secure Computation. In *Proc. of STOC*, pp. 494–503, 2002.
- [19] R. Canetti and T. Rabin. Universal Composition with Joint State. In *Proc. of Crypto 2003*, Springer-Verlag, pp. 265–281, 2003.
- [20] I. Damgard and J. Nielsen. Perfect Hiding and Perfect Binding Universally Composable Commitment Schemes with Constant Expansion Factor. In *Proc. of Crypto*, Springer-Verlag, pp. 581–596, 2002.
- [21] Y. Dodis and S. Micali. Parallel Reducibility for Information-Theoretically Secure Computation. In *Proc. of Crypto*, Springer-Verlag (LNCS 1880), pp. 74–92, 2000.
- [22] U. Feige. Alternative Models for Zero Knowledge Interactive Proofs. Ph.D. thesis, Weizmann Institute of Science, Rehovot, Israel, 1990.
- [23] U. Feige and A. Shamir. Zero knowledge proofs of knowledge in two rounds. In G. Brassard, editor, *Advances in Cryptology—CRYPTO '89*, volume 435 of *Lecture Notes in Computer Science*, pages 526–545. Springer-Verlag, 1990, 20–24 Aug. 1989.
- [24] S. Goldwasser, and L. Levin. Fair Computation of General Functions in Presence of Immoral Majority. *CRYPTO '90*, LNCS 537, 1990.
- [25] S. Goldwasser, S. Micali, C. Rackoff. The Knowledge Complexity of Interactive Proof Systems. *SIAM Journal on Computation*, 18(1):186–208, 1989.
- [26] O. Goldreich, S. Micali, and A. Wigderson. How to Solve any Protocol Problem. In *Proc. of STOC*, 1987.
- [27] O. Goldreich, S. Micali, and A. Wigderson. Proofs that yield nothing but their validity or all languages in NP have zero-knowledge proof systems. *Journal of the ACM*, 38(1):691–729, 1991.

- [28] D. Hofheinz, J. Muller-Quade, and D. Unruh. Universally Composable Zero-Knowledge Arguments and Commitments from Signature Cards. In *Proc. of the 5th Central European Conference on Cryptology MoraviaCrypt 2005*, June 2005.
- [29] M. Jakobsson, K. Sako, and R. Impagliazzo. Designated Verifier Proofs and their Applications. In *Proc. of Eurocrypt*, Springer-Verlag, 1996.
- [30] Y. Lindell. General Composition and Universal Composability in Secure Multi-Party Computation. In *Proc. of FOCS*, Springer-Verlag, pp. 394–403, 2003.
- [31] S. Micali and P. Rogaway. Secure Computation. unpublished manuscript, 1992. Preliminary version in *CRYPTO '91, LNCS 576*, 1991.
- [32] P. MacKenzie and K. Yang. On Simulation-Sound Trapdoor Commitments. In *Proc. of Eurocrypt*, Springer-Verlag (LNCS 3027), pp. 382–400, 2004.
- [33] R. Pass. On Deniability in the Common Reference String and Random Oracle Model. In *Proc. of Crypto*, LNCS 2729, pp. 216–337, 2003.
- [34] R. Pass. Bounded-Concurrent Secure Multi-Party Computation with a Dishonest Majority. In *Proc. of STOC*, pp. 232–241, 2004.
- [35] M. Prabhakaran and A. Sahai. New Notions of Security: Achieving Universal Composability without Trusted Setup. In *Proc. of STOC*, 2004.
- [36] B. Pfitzmann and M. Waidner. Composition and Integrity Preservation of Secure Reactive Systems. In *Proc. of ACM CCS*, pages 245–254, 2000.
- [37] F. Zhang, R. Safavi-Naini and W. Susilo. ID-Based Chameleon Hashes from Bilinear Pairings. Available at <http://eprint.iacr.org/2003/208/>.