

A Network Pricing Game for Selfish Traffic

Extended Abstract

Ara Hayrapetyan*
Cornell University
Dept. of Computer Science
4106 Upson Hall
Ithaca, NY 14853, USA
ara@cs.cornell.edu

Éva Tardos†
Cornell University
Dept. of Computer Science
5153 Upson Hall
Ithaca, NY 14853, USA
eva@cs.cornell.edu

Tom Wexler‡
Cornell University
Dept. of Computer Science
4106 Upson Hall
Ithaca, NY 14853, USA
wexler@cs.cornell.edu

ABSTRACT

The success of the Internet is remarkable in light of the decentralized manner in which it is designed and operated. Unlike small scale networks, the Internet is built and controlled by a large number of disparate service providers who are not interested in any global optimization. Instead, providers simply seek to maximize their own profit by charging users for access to their service. Users themselves also behave selfishly, optimizing over price and quality of service. Game theory provides a natural framework for the study of such a situation. However, recent work in this area tends to focus on either the service providers or the network users, but not both. This paper introduces a new model for exploring the interaction of these two elements, in which network managers compete for users via prices and the quality of service provided. We study the extent to which competition between service providers hurts the overall social utility of the system.

Categories and Subject Descriptors

F.0 [Theory of Computation]: General—*Game Theory*

General Terms

Theory, Economics

Keywords

Game Theory, Network Pricing Games, Price of Anarchy.

*Supported in part by NSF ITR grant CCR-0325453.

†Supported in part by NSF grant CCR-0311333, ITR grant CCR-0325453, and ONR grant N00014-98-1-0589.

‡Supported in part by NSF ITR grant CCR-0325453.

Permission to make digital or hard copies of all or part of this work for personal or classroom use is granted without fee provided that copies are not made or distributed for profit or commercial advantage and that copies bear this notice and the full citation on the first page. To copy otherwise, to republish, to post on servers or to redistribute to lists, requires prior specific permission and/or a fee.

PODC'05, July 17–20, 2005, Las Vegas, Nevada, USA.

Copyright 2005 ACM 1-59593-994-2/05/0007 ...\$5.00.

1. INTRODUCTION

One of the most surprising features of the Internet is how effectively it operates on a global scale, despite the fact that its various components (Autonomous Systems) are operated by separate service providers, each of whom seeks only to maximize their own income. A number of recent papers have considered competitive network design games as simple models of how selfish agents might construct such a network. These models tend to assume a static user population, typically with fixed demands. In this paper we address the fact that the potential network users are just as crucial to the construction of a network as the service providers themselves. Network managers compete for users via prices and the quality of service provided. We propose a simple game to explore a basic question that arises in this situation: how is the quality of service affected when the service providers set prices so as to extract maximum profit? We consider the special case of a graph with parallel links (or scheduling parallel machines), where the quality of the service is modeled as delay that increases linearly with the congestion, and user demand is concave. For such a game, we show that a pure equilibrium exists, and we provide a constant factor bound on the *price of anarchy*, which roughly speaking measures the inefficiency of competitive play. We give an improved bound for the special case in which delay is a pure congestion effect (when delay is 0 with no congestion).

Selfish routing and network design are two important classes of network games that have received much attention in recent years. In work on selfish routing (or load balancing) [10, 11, 12, 16, 19, 20, 21, 22] users in a network route their traffic selfishly with the aim of minimizing their latency. These papers show bounds on the price of anarchy in the corresponding games, that is, they give bounds on the performance degradation caused by the selfish routing as compared to a centrally designed optimal solution. In these games the sole selfish goal of users is to minimize the delay; in particular, user demand is fixed (independent of the delay in the system), and the network is passive, in that it does not try to effect routing behavior by changing the properties of its edges.

Network games have also been used to try to understand the quality of networks built by selfish agents. The price of anarchy or price of stability for such network creation games were studied under a few related models [5, 6, 13]. Such network creation games aim to model the behavior of agents, such as Autonomous Systems, who seek to build networks. However, the models considered here also assume that demand is fixed, and not dependent on the properties of the constructed network. In particular, network design games typically cannot model congestion effects. Furthermore, these models assume that network builders want to simply build a cheap network

satisfying user demand, rather than maximizing their own income by charging users for access to this network.

The primary motivation of this paper is to develop a model that encompasses key aspects of both selfish routing and network design games. Our main result is a small constant bound on the price of anarchy in a game that combines profit-maximizing edge-pricing players with user demand that is sensitive to both prices and congestion. In our model, users perceive the quality of a route (path) in a network via a combination of prices and congestion. Edges have congestion sensitive delays, i.e. the time required to traverse an edge depends on the amount of traffic using it. To this extent, our model extends the work on selfish routing discussed above. However, we will also assume that each edge is operated by a distinct selfish player, who can charge traffic for the use of that edge. Finally, we assume that user demand is affected by the quality of service provided, in that increasing prices and delay lead to decreasing user traffic. We assume that the edges set prices in a selfish manner, aiming to maximize their income. The goal of our work is to quantify the performance degradation caused by selfishness (the price of anarchy) in this model. We show that in the special case of networks with parallel links and linear delays, pure Nash equilibria exist and the price of anarchy is bounded by a small constant.

Our Model.

We define a simple model that combines the issues mentioned above. We consider a network consisting of two nodes s and t , with k parallel links. Each link is controlled by a distinct player, who can charge traffic a price for use of her link. One can also view this game as modeling a type of selfish load balancing problem. Here the edges correspond to machines, and the flow or traffic will selfishly balance between them. Each machine has a load dependent delay, and it can charge a price to all users.

Link i (or machine i) has a latency (or delay) function $\ell_i(x)$, indicating the delay experienced by a volume of x traffic using i . We will primarily focus on strictly increasing linear latencies, i.e. $\ell_i(x) = a_i x + b_i$, where $a_i > 0$ and $b_i \geq 0$. We assume that user experience in routing flow through link i depends on the sum of the price and the latency, which we will call the *disutility*. More precisely, if player i charges p_i and f_i volume of flow uses link i , then that flow experiences a disutility of $p_i + \ell_i(f_i)$.

We assume that traffic routes itself *selfishly*, meaning that traffic will not route along one link if it can switch links and incur a lower disutility. As a result, all traffic will necessarily experience the same disutility.

Finally, we also assume that the total amount of traffic from s to t is dependent on the disutility that traffic experiences; as the disutility increases, the total amount of flow interested in routing from s to t decreases. We model this with a demand function $D(y)$, also referred to as the *demand curve*, which indicates the amount of flow willing to incur a disutility of y . We will naturally assume that demand $D(y)$ is decreasing in disutility y . We will focus on demand curves that are continuous and concave. Different demand curves are used to model demand in different industries. A concave demand curve is applicable for modeling demand for a service with a comparable alternative (at a high enough price all users will switch to the alternate service).

It will often be useful for us to consider $u(x) = D^{-1}(x)$, which we call the *disutility curve*. This measures the disutility that will be tolerated by a volume of x flow. By definition, $u(x)$ is also decreasing and concave. For ease of exposition, we will assume that $u(x)$ is strictly decreasing, but this assumption can be dropped without substantially changing our results.

To define our problem more precisely, we say that a price vector

p induces a flow vector f satisfying the following properties.

1. For any i, j if $f_i > 0$, then $\ell_i(f_i) + p_i \leq \ell_j(f_j) + p_j$.
2. If $f_i > 0$ then $\ell_i(f_i) + p_i = u(\sum_j f_j)$.

The first condition ensures that no traffic can decrease its disutility by rerouting. The second condition states that the disutility experienced by any traffic must match the the disutility that is tolerated by the given volume of flow. It is not hard to see that since the demand is continuous and decreasing, such flows always exist, and since latencies are strictly increasing, these flows are unique as well.

We may now complete the definition of the game. Each player i selects a price p_i for her link. These prices, together with the latencies and the demand curve, induce a unique flow f_i on each link. Players seek to maximize their profit, $\pi_i = p_i \cdot f_i$. We say that a set of prices p is at *Nash equilibrium* if, by changing a single price p_i to p'_i , the resulting flow f' does not give player i a larger profit ($\pi'_i = p'_i \cdot f'_i$).

For a set of prices, we are interested in measuring the *social utility* of a given solution. For a solution with prices p inducing total flow $F = \sum_j f_j$, and disutility d , we define the social utility to be

$$U(p) = \sum_i \pi_i + \int_0^F (u(x) - d) dx.$$

The first term accounts for players' profits, and the second terms represents the utility gathered by the traffic that gets routed. An example of an instance of the game with two links is shown in Figure 1. The social utility of this instance is indicated by the shaded area.

We will be interested in bounding the *price of anarchy* of this game. If p^* is the set of prices that maximizes social utility, then the *price of anarchy* is the maximum possible ratio of

$$\max_p \frac{U(p^*)}{U(p)},$$

where the prices p range over the possible equilibrium prices. Note that the total area under $u(x)$ provides an upper bound on the maximum possible social utility. However, to achieve this bound we would need to route the maximum possible traffic volume without incurring any delay.

We note that there are other reasonable measures of social utility; we could have considered either the players' profits or the users' utility as social welfare functions. However, the sum of these two objectives seems the most reasonable if we take the economic perspective, in which money is transferable. Furthermore, under either measure alone, simple examples demonstrate an unbounded price of anarchy.

We can think of our problem as a type of two-stage game where there are two types of players: the owners of the edges, and the users with traffic. In the first stage, the edge-players set prices p_i on edges. In the second stage, traffic routes itself selfishly from the source to the sink with respect to new latencies $\ell_i(x) + p_i$, where the rate of flow is dictated by the disutility curve. For the remainder of this paper, we will focus on the first stage of this game, the game of setting prices, and will assume that players anticipate the flow resulting from their chosen prices. However, the existence and uniqueness of these flows follow directly from observing this connection.

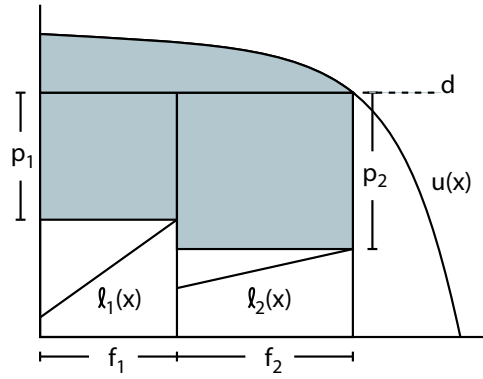

Figure 1: An instance of the network pricing game with two players.

Our Results.

- We show that for our pricing game, in a network with parallel links, concave demand and linear delays, there is always a pure Nash equilibrium.
- Furthermore, we bound the price of anarchy in this game by 5.064, even when delays are relaxed to be convex.
- In the special case when delay is exclusively a congestion effect, that is, all links have $\ell_i(0) = 0$, the price of anarchy is bounded by at most 3.125.

Related Work.

In our model traffic evaluates its experience via a combination of price and delay. Modelling traffic as experiencing disutility in terms of price and delay has been studied in the transportation literature as early as in 1920 [18] (see also [7]) and more recently in a sequence of papers started by Cole, Dodis and Roughgarden [8, 9] (see also [14, 15]). These works view prices as a tax that is set by a benevolent network manager so as to improve network performance. Acemoglu and Ozdaglar [2] consider a version of our pricing problem in a monopolistic setting with fixed demand. They assume that all edges are owned by a single service provider, and focus on establishing the existence of an equilibrium and characterizing this equilibrium. More recently, after we obtained our results, the same authors extended their model to oligopolies, while still assuming fixed demand and delays which are exclusively due to congestion, i.e. $\ell_i(0) = 0$ for all i (see [1]). They thereby analyzed a special case of our model and proved a tight bound of 6/5 for the price of anarchy. Along different lines, Vetta [23] shows a nice bound on the price of anarchy in a two-stage pricing game for facility location. In Vetta's game the players' strategies are the facilities they select, and prices are determined based on the facility locations, much as our prices determine the flow through the system.

There is a large body of economics literature dedicated to understanding the effects of pricing with service delays, with the focus being on establishing the existence of stable equilibria, and considering qualitative properties of equilibria (such as whether improved service leads to improved profit). Lee and Mason [17] consider the most closely related model with identical links and non-uniform users. More complex models are discussed in the recent papers by Allon and Federgruen [4] and Afèche [3] and their references. Just as in our work, these papers assume that user experience depends

on a combination of price and delay, and that prices are set by selfish, income-maximizing players. However, these papers consider more complex environments, including heterogeneous users, and situations in which not only prices, but also delays can be used as strategic variables. However, unlike our work, these papers do not provide bounds on the quality degradation caused by selfish pricing.

Paper Organization.

The remainder of this paper is organized as follows. In section 2, we prove that pure Nash equilibria always exist in this game. In doing so, we first prove a number of lemmas that will be useful throughout the paper. We present our main result in section 3, where we argue that the price of anarchy in this game is bounded by a small constant. In section 4, we consider alternate classes of demand and latency functions. In particular, we show that pure equilibria may not exist if latencies are convex, although when they do, our price of anarchy result still applies. We also argue that in the presence of convex demand, the price of anarchy may be unbounded.

2. EXISTENCE OF PURE EQUILIBRIA

We say that a player is *content* if she has no incentive to deviate from her current price. To prove that pure Nash equilibria exist, it will be critical to relate the price charged by a content player to the flow she receives, and to the slopes of the latency and disutility functions. This is achieved through the following technical lemma, which will also play a key role in later bounding the price of anarchy.

Lemma 2.1 *Let p be the price vector chosen by the players and f be the corresponding flow vector, with total flow $F = \sum_i f_i$. Define v^- and v^+ respectively as the left and right derivatives (slopes) of the disutility curve at F . We will assume that v^- and v^+ are both well defined (note that they are both negative), though they do not have to be equal. If player i is content, then the following two conditions must hold:*

1. $(\frac{p_i}{f_i} - a_i)(\sum_{j \neq i} \frac{1}{a_j} - \frac{1}{v^-}) \geq 1$
2. $(\frac{p_i}{f_i} - a_i)(\sum_{j \neq i} \frac{1}{a_j} - \frac{1}{v^+}) \leq 1$.

Observe that equality must hold if the disutility curve is continuously differentiable at F .

Before proving this, we establish some basic results concerning the monotonicity and continuity of this game. We first show that

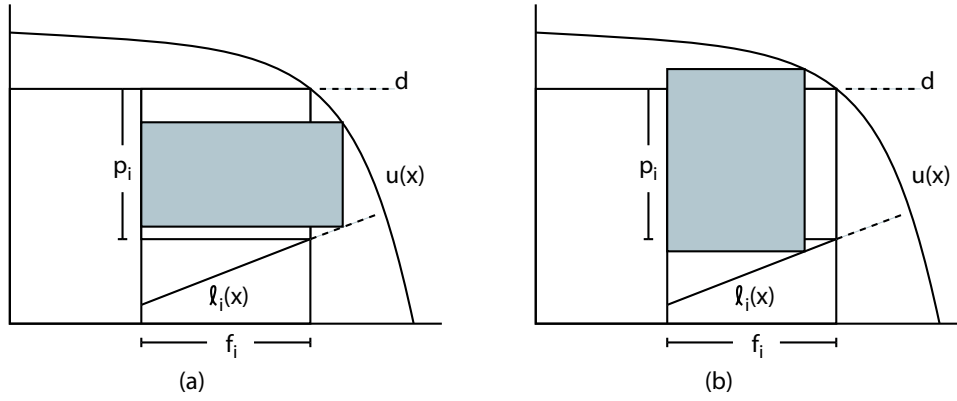

Figure 2: The immediate effect of a player (a) decreasing and (b) increasing her price.

if a single player changes her link price, the flow induced by all players' prices changes in the natural way. In particular, if a player increases her price, the newly induced flow will route less traffic on her link, at least as much traffic on every other link, and less traffic in total. Similarly, the symmetric claims hold if the player decreases her price. More precisely we have

Lemma 2.2 *Let p_1, \dots, p_k be a price vector with associated flow vector f_1, \dots, f_k . Assume that the first player increases her price to $p'_1 > p_1$ while the others keep their prices unchanged. Denote the new flow vector by f'_1, \dots, f'_k . If $f_1 > 0$, then,*

1. $f'_1 < f_1$,
2. $f'_i \geq f_i$, for all $i \neq 1$.
3. $F' \leq F$, where $F = \sum_i f_i$ and $F' = \sum_i f'_i$.

The symmetric claim holds if player 1 reduces her price.

PROOF. We will assume without loss of generality that there are at least two players with positive flow, since otherwise the claims are trivial.

1) Suppose the flow on link 1 does not decrease. Then, since the price increased, the disutility must strictly increase. Consider any other link that had positive flow. This link now has greater disutility, and since the price has not changed, must carry more flow. But this implies that both the disutility and total flow have increased, which is a contradiction.

2) Suppose some link $i \neq 1$ loses flow. Since p_i is unchanged and latencies are strictly increasing, the disutility must strictly decrease. This implies that all links that carried flow must now carry less flow. Since we know that link 1 loses flow, the total flow decreases. But then both the disutility and the total flow have decreased, which is a contradiction.

3) Finally, since flow on any link other than 1 can only increase, the disutility can only increase, and thus the total volume of flow can only decrease. \square

The next lemma argues that the amount of flow routed along any link is a continuous function of the players' prices.

Lemma 2.3 *Let p be a price vector and let $f_i(p_i)$ be the amount of flow routed through link i as a function of p_i (assuming all other prices in p are fixed). Then the function $f_i(p_i)$ is non-increasing and continuous for any p .*

PROOF. The non-increasing part follows from Lemma 2.2. As for continuity, we again prove by contradiction. We will argue that if there is a discontinuity, a small change in price can be found that violates monotonicity of disutility. For some price vector p let p_i be a point of discontinuity of $f_i(\cdot)$. Let f be the flow vector corresponding to the prices p with player i charging p_i . Assume without loss of generality that $f_i(\cdot)$ is upper-discontinuous at p_i . Then there exists a small $\Delta > 0$ such that for any $\epsilon > 0$, if player i increases p_i by ϵ , the flow going through the i^{th} link will decrease by at least Δ (notice that it must decrease by Lemma 2.2). Since latencies are strictly monotone, the loss of at least Δ flow decreases the latency on link i by at least some $L > 0$. Choose $\epsilon < L$. Then if player i selects a price of $p_i + \epsilon$, the resulting latency will more than offset the increase in price. Thus the disutility will strictly decrease, contradicting Lemma 2.2. \square

Having shown that flow is a continuous function of price, it is not difficult to extend this result to show continuity of profit. Indeed, application of elementary analysis yields the following.

Lemma 2.4 *Let $\pi : \mathbb{R}^k \mapsto \mathbb{R}^k$ be the function mapping a vector of prices p to the vector of profits obtained by the players when they charge the corresponding prices, i.e. $\pi(p) = (\pi_1, \dots, \pi_k)$ means that the profit of player i is π_i under the price vector p . Then the function $\pi(\cdot)$ is a continuous function of p .*

This continuity allows us to prove Lemma 2.1.

PROOF OF LEMMA 2.1. The intuition behind the proof of this lemma is based on the following observations. For a player i to be content, she must not be able to benefit by changing her price at all. The lemma will follow from observing that, in particular, she will not benefit from very small changes to her price. Intuitively, the gain from an increase in price must be outweighed by the resulting loss of flow. In Figure 2 the shaded boxes indicate the immediate effect of a player increasing or decreasing her price *without* taking into account the resulting change in flow of the other players. The actual resulting flow depends not only on player i 's latency function, but also on the disutility curve (determining how much flow leaves the system altogether), and other players' latencies (determining how much flow they steal). For sufficiently small increases in price, the magnitude of this loss is dictated solely by the local slopes of these curves, resulting in the first inequality. Likewise, the second inequality follows by considering a small decrease in price.

More formally, let us prove the second inequality. The proof for the first one is analogous. Assume that player i changes her price

so that the system disutility is decreased by a tiny amount $\delta > 0$. Then the flow of a player $j \neq i$ will decrease by δ/a_j and the total flow in the system will increase by $-\delta/v^+$ ¹. Hence player i 's flow must increase by $\Delta f_i = \delta(\sum_{j \neq i} \frac{1}{a_j} - \frac{1}{v^+})$. This increase in flow will result to a latency increase of $a_i \cdot \delta(\sum_{j \neq i} \frac{1}{a_j} - \frac{1}{v^+})$. So i must decrease her price by $\Delta p_i = \delta + a_i \cdot \delta(\sum_{j \neq i} \frac{1}{a_j} - \frac{1}{v^+})$.

We next observe that for any $\epsilon > 0$, there exists a small enough δ such that, $\Delta p_i/\Delta f_i \geq p_i/f_i - \epsilon$. Indeed, if $\Delta p_i/\Delta f_i < p_i/f_i - \epsilon$ then $p_i \Delta f_i > f_i \Delta p_i + f_i \Delta f_i \epsilon$. Now player i can obtain more profit by setting her price to $p_i - \Delta p_i$, because her new profit would be $(p_i - \Delta p_i)(f_i + \Delta f_i) = p_i f_i - f_i \Delta p_i + p_i \Delta f_i - \Delta p_i \Delta f_i > p_i \cdot f_i$ if we choose δ small enough to ensure that $\epsilon f_i > \Delta p_i$ (which we can do due to continuity of latencies and demand). But this can not happen, since player i was content. Thus in the limit of δ approaching 0 we get $\Delta p_i/\Delta f_i \geq p_i/f_i$.

Therefore as δ tends to 0,

$$\begin{aligned} \delta + a_i \cdot \delta \left(\sum_{j \neq i} \frac{1}{a_j} - \frac{1}{v^+} \right) &= \Delta p_i \geq \frac{p_i}{f_i} \Delta f_i \\ &= \frac{p_i}{f_i} \cdot \delta \left(\sum_{j \neq i} \frac{1}{a_j} - \frac{1}{v^+} \right). \\ 1 + a_i \left(\sum_{j \neq i} \frac{1}{a_j} - \frac{1}{v^+} \right) &\geq \frac{p_i}{f_i} \left(\sum_{j \neq i} \frac{1}{a_j} - \frac{1}{v^+} \right), \\ \left(\frac{p_i}{f_i} - a_i \right) \left(\sum_{j \neq i} \frac{1}{a_j} - \frac{1}{v^+} \right) &\leq 1. \end{aligned}$$

□

We can now analyze the best response function $\beta : \mathbb{R}^k \mapsto \mathbb{R}^k$. This function maps a price vector p to another price vector p' , such that p'_i maximizes player i 's profit assuming all other players price as in p . We define player i 's best response to be $p_i = 0$ if there is no price at which i can derive a positive profit. We will use Lemma 2.1 to show that a player's best response is unique, and hence the $\beta(p)$ is well defined. This and the continuity of $\beta(\cdot)$ will be sufficient to prove the existence of pure equilibria.

Lemma 2.5 *For any set of existing prices p , all players' best response is unique (and hence the $\beta(p)$ is well defined). Furthermore $\beta(\cdot)$ is a continuous function of p .*

PROOF. Suppose that the best response for some player i is not unique, and let $p'_i > p''_i$ be two best response prices for player i . Let f' and f'' be the corresponding flow vectors when player i selects prices p'_i and p''_i respectively, with corresponding total flow F' and F'' . Lemma 2.2 implies that $f'_i < f''_i$ and $F' < F''$. Let v' denote the right slope of $u(\cdot)$ at F' and v'' denote left slope of $u(\cdot)$ at F'' . By concavity of $u(\cdot)$, $v' \geq v''$ (recall that both values are negative).

Since both p_i and p''_i are best responses for player i , we can apply Lemma 2.1:

$$1 \geq \left(\frac{p'_i}{f'_i} - a_i \right) \left(\sum_{j \neq i} \frac{1}{a_j} - \frac{1}{v'} \right) > \left(\frac{p''_i}{f''_i} - a_i \right) \left(\sum_{j \neq i} \frac{1}{a_j} - \frac{1}{v''} \right) \geq 1.$$

This is a contradiction, and thus a players best response must be unique. The continuity of $\beta(\cdot)$ is a direct consequence of the continuity of $\pi(\cdot)$ (Lemma 2.4). □

¹To be formal, we have to take a sequence of δ 's approaching 0.

Since there is a maximum price P such that any player charging above P gathers no profit, we can restrict our attention on $\beta(\cdot)$ to the convex and compact region $[0, P]^k$. Thus we can apply Brouwer's fixed point theorem and thereby prove the following.

Theorem 2.6 *The network pricing game has a Nash equilibrium.*

3. PRICE OF ANARCHY

In this section we prove our main result, namely that selfish behavior on the part of the players yields a social utility that is within a small constant factor of optimal. More formally, we prove

Theorem 3.1 *The price of anarchy for the network pricing game is at most 5.064.*

The first step is to take a general instance of a game with prices at Nash equilibrium, and create a new game instance in which the equilibrium gathers no traffic utility (see Figure 3). In doing this we preserve the original equilibrium, and only increase the price of anarchy. Now, in this modified game, we can bound the social utility of an optimal solution solely against the player profit at Nash equilibria.

We will consider a general instance of the game with disutility function u and latencies $\ell_i(\cdot)$ for $1 \leq i \leq k$. We assume we have a price vector p at Nash equilibrium, with induced flow vector f , total flow volume F and disutility d .

Lemma 3.2 *Define a new disutility curve*

$$w(x) = \begin{cases} d & \text{if } x < F \\ u(x) & \text{otherwise} \end{cases}$$

Then prices p are also at Nash equilibrium given this truncated demand curve, and the price of anarchy of this instance has not decreased.

PROOF. Clearly no player has an incentive to decrease her price, as this would increase the total flow, and thus yield a flow vector that was achievable under $u(x)$. But we assumed that p was at equilibrium for $u(x)$, so this can not benefit any player. Furthermore, no player has an incentive to increase their price, as the potential gain of any such move is strictly smaller than it would have been prior to the truncation.

As for the price of anarchy, note that this truncation destroys all traffic utility of the given equilibrium, as shown in Figure 3. But this is also an upper bound on the decrease in the social utility of the new optimal solution under the truncated disutility curve. Thus the price of anarchy can only increase. □

The next lemma provides a simple lower bound on the price that players charge at equilibrium, both in terms of the system disutility d and their own latency function. This result will clearly be useful in lower bounding player profits in the Nash equilibrium.

Lemma 3.3 *At equilibrium, any player i charges $p_i \geq \frac{d-b_i}{2}$, where $b_i = \ell_i(0)$.*

PROOF. For simplicity, we will assume we have a truncated disutility curve, although the lemma is also true without this assumption. Define $q = d - b_i$. We will claim that if player i charged $p_i < \frac{q}{2}$, then she can increase her profit by charging $\frac{q}{2}$. Observe that $a_i \cdot f_i + b_i + p_i = d$. Thus we can express

$$\pi_i = p_i \cdot f_i = p_i(q - p_i)/a_i < \frac{q^2}{4a_i}.$$

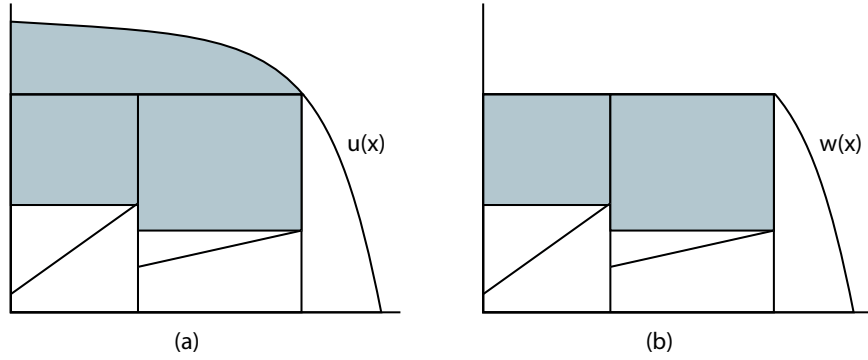

Figure 3: A disutility curve with prices and flows at equilibrium and the corresponding truncated curve.

However, since we are assuming a truncated demand curve, in charging $\frac{p}{2}$, the resulting flow f' would be determined solely by $\ell_i(x)$. Hence, f' satisfies the same condition, i.e. $a_i \cdot f' + b_i + \frac{q}{2} = d$. Thus the profit would be exactly $\frac{q^2}{4a_i}$. \square

We now prove our main result. We consider an instance of our game with equilibrium prices p , and corresponding flow vector f , total flow F , and disutility d . We assume that our disutility function $u(x)$ is truncated as in Lemma 3.2, i.e. $u(x) = d$ on the interval $[0, F]$, and thus $U(p)$ is represented entirely by player profit.

PROOF OF THEOREM 3.1. As observed, in our truncated instance of the game, the given Nash equilibrium generates no traffic utility. Thus we must bound both the player profit and traffic utility of the optimal solution against the profit of the players at Nash equilibrium. We will consider an optimal price vector p^* , with corresponding flows f^* , F^* , and disutility value d^* . We can trivially bound the traffic utility of the optimal solution by $F^* \cdot (d - d^*)$, and we can attribute $f_i^* \cdot (d - d^*)$ of this bound to each player i . Thus we will think of each player i in the optimal solution as contributing $\pi_i^* + f_i^* \cdot (d - d^*)$ to $U(p^*)$.

We first partition the players by the slope of their latencies. More precisely, let us call a player *steep* if $a_i \geq \frac{1}{2} \frac{p_i}{f_i}$. Otherwise, we will say a player is *shallow*. We will now argue that there is at most one shallow player. Then we will show that the contribution of a steep player i to the optimal solution can be bounded in terms of π_i . Finally, we consider two cases regarding the shallow player's latency. In both cases, we show that the contribution of this shallow player to the optimal solution can be bounded within a constant factor of the sum of the profits of all the players at Nash equilibrium.

Let v^+ be the right slope of $u(x)$ at F . Consider any shallow player i . By Lemma 2.1, we know that $(\frac{p_i}{f_i} - a_i)(\sum_{j \neq i} \frac{1}{a_j} - \frac{1}{v^+}) \leq 1$. Since i is shallow, the first term is greater than $\frac{p_i}{2f_i}$. But v^+ is negative, so for all $j \neq i$ we must have $a_j > \frac{p_i}{2f_i} > a_i$, as otherwise the above inequality would be violated. This implies that i must have the unique minimum slope, and thus i must be the only shallow player.

Consider a steep player j . As in the proof of Lemma 3.2, we can argue that the optimal solution can not gather more value than π_j by charging more than p_j , as then the player could selfishly do the same. Thus we only need to consider how the optimal solution might benefit by having $p_j^* < p_j$. By assumption, $a_j \geq \frac{1}{2} \frac{p_j}{f_j}$. The maximum feasible rectangle (corresponding to gathered utility) that is bounded above by $u(x)$ and below by $\ell_j(x)$ has an area of $1.125\pi_j$, which is achieved when $a_j = \frac{1}{2} \frac{p_j}{f_j}$ by setting a price of $\frac{3}{4}p_j$ and inducing a flow of $\frac{3}{2}f_j$. Thus nearly all players gather almost as much utility as they would in an optimal solution.

Now we are left with the task of bounding the value gathered by the shallow player i in the optimal solution. We again know that to gather more value with i , the optimal solution must charge a lower price and carry more flow, as any benefit in raising the price could also be realized by the player at equilibrium. Thus our concern is that somehow the optimal solution sends a huge amount of flow at lower price on i , thereby gathering substantially larger social utility. We consider two cases, based on just how shallow i 's latency is.

Case 1: $\ell_i(4f_i) - \ell_i(f_i) > p_i/4$. In this case the latency is not very shallow, and we can simply bound the maximum contribution of player i to the optimal solution by ignoring all other players and assuming $u(x) = d$. Then the best choice for i is to charge $\frac{d-b_i}{2}$ (thereby maximizing the area of a rectangle inscribed in a triangle). Given our condition on ℓ_i , this can be shown to yield a profit of at most $3.52\pi_i$.

Case 2: $\ell_i(4f_i) - \ell_i(f_i) \leq p_i/4$. This case deals with a very shallow latency. A trivial upper bound on the amount that the optimal solution can gather through i is

$$\int_0^r (u(x) - \ell_i(f_i)) dx$$

where r is defined by $u(r) = \ell_i(f_i)$. This is the value i could gather in the absence of other players if $\ell_i(x)$ never exceeded $\ell_i(f_i)$. We will partition this area into two regions; A , representing $\int_0^r (u(x) - \ell_i(f_i)) dx$, and B , representing the rest, with area $F(d - \ell_i(f_i))$, as shown in Figure 4(a).

To bound A , recall that $a_i < \frac{1}{2} \frac{p_i}{f_i}$. Since the slope of i 's latency is shallow, the disutility curve must be relatively steep, as otherwise, i could decrease p_i slightly and dramatically increase f_i . More precisely, Lemma 2.1 implies that $v^+ \leq -\frac{1}{2} \frac{p_i}{f_i}$. Since $u(x)$ is concave, the area in A can be upper bounded by a triangle of height p_i and slope v^+ . This has area at most $p_i \cdot f_i = \pi_i$.

To bound B , we partition the steep players (all $j \neq i$) into two classes. Let S^- be the set of all players j for whom $b_j > \ell_i(f_i) + p_i/2$, and let S^+ consist of all remaining steep players, as shown in Figure 4(b). Define F^- and F^+ to be the total flow carried by all players in S^- and S^+ respectively at equilibrium. By Lemma 3.3, we know that for any player $j \in S^+$, $p_j \geq (d - b_j)/2$, and hence the total profit of all players in S^+ is at least $p_i F^+/4$. Furthermore, we can argue that S^- must be small, as if it was very large, player i would have an incentive to undercut all the players in S^- . In particular, we claim that $F^- \leq 3f_i$. Otherwise, player i would have an incentive to charge a quarter of her current price. Due to the above shallowness condition on her latency, she is guaranteed

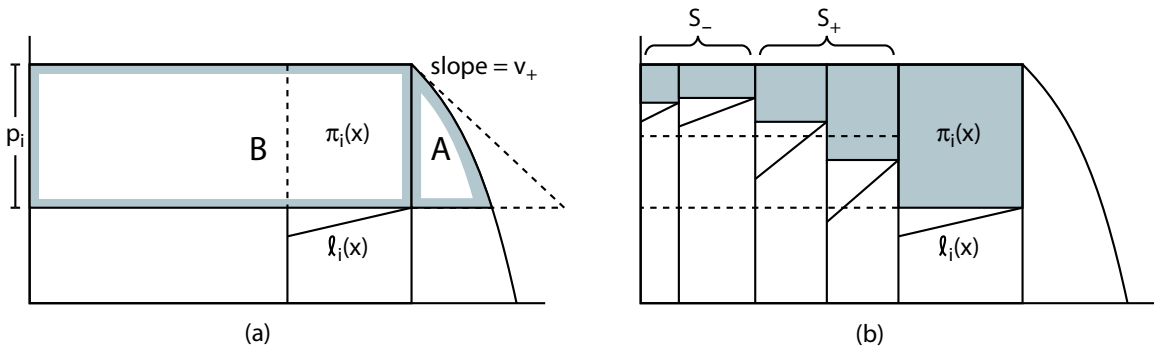

Figure 4: (a) The regions A and B for the shallow player, (b) Partitioning the steep players into S^- and S^+ .

to more than quadruple her flow before any player in S^- routes any traffic. Clearly this would generate more profit, contradicting our assumption of equilibrium. Thus we can bound the total area of B by $4\pi_i + 4 \sum_{j \neq i} \pi_j$.

The combined area of A and B is thus at most $5\pi_i + 4 \sum_{j \neq i} \pi_j$, and hence the optimal solution can gather a value of no more than $5\pi_i + 5.125 \sum_{j \neq i} \pi_j$. Thus the price of anarchy is at most 5.125.

If we return to our bound on the area of B , note that we can generalize our definition of S^- to be the set of all players j for whom $b_j > \ell_i(f_i) + \alpha p_i$ for some real α , and define S^+ similarly. Optimizing over α yields the desired bound of 5.064. \square

For the special case when $\ell_i(0) = 0$ for all i , a proof similar to the one above yields the following

Theorem 3.4 *The price of anarchy of the network pricing game with a concave demand curve and linear latencies of the form $\ell_i(x) = \alpha_i x$ is bounded by 3.125.*

To conclude this section we show that the price of anarchy is lower bounded by $3/2$.

Observation 3.5 *There exists a 1-player instance of the network pricing game with linear latencies and concave demand curve which has a price of anarchy of $3/2$.*

PROOF. Consider the disutility curve $u(x) = 1$ for $0 \leq x \leq 1$ and $u(x) = 2 - x$ for $1 \leq x \leq 2$ and let the player have zero latency. Then she would obtain maximal profit of 1 by charging a price of 1 for a social value of 1. Yet the optimal solution can gather a social value of $3/2$ by charging 0. Hence the lower bound. Finally, it is not difficult to slightly modify this example to ensure (strict) monotonicity of latency and demand curves. \square

Remark: It is not difficult to prove that for a single player the bound $3/2$ is tight.

4. EXTENSIONS AND RELATED MODELS

In this section we analyze what happens to the network pricing game when we relax the assumptions on the latency functions and the demand curve. First, we consider convex, as opposed to linear, latency functions, while retaining concave demand.

Unfortunately, the network pricing game with convex latencies and concave demand curve may not have a Nash equilibrium as illustrated by the following 2-player example. Let the disutility curve be the unit box: $u(x) = 1$ for all $0 \leq x \leq 1$ and $u(x) = 0$

otherwise. Define the players' latencies as $\ell_1(x) = 0$ for all x , and $\ell_2(x) = 1/3$ for all $0 \leq x \leq 1/3$ and $\ell_2(x) = \infty$ otherwise. We claim that this instance of the game has no Nash equilibrium. Indeed, assume that there is a Nash equilibrium with total disutility d . If $d \leq 1/3$ then the first player must make a profit of no more than $1/3$. Yet she has a guaranteed profit of $2/3$ if by charging 1. If $d > 1/3$, then for the second player to be content, she has to charge a price of $d - 1/3$, and thus the first player can earn a profit of at most $2d/3$ by charging d . But then if the first player reduces her price slightly to $d - \epsilon$ then all the flow will route through her link and she will earn a profit of $d - \epsilon > 2d/3$. Hence the game has no Nash equilibrium. Although the above example violates continuity and strict monotonicity of the latency functions and the demand curve, it is not difficult to alter it slightly so as to satisfy these conditions while still maintaining the nonexistence of Nash equilibrium.

On the other hand, when such a network pricing game does have a Nash equilibrium, the proofs of the previous sections can be extended to yield the same bounds on the price of anarchy.

Theorem 4.1 *If an instance of the network pricing game with convex latencies and concave demand has a Nash equilibrium, then the price of anarchy is bounded by 5.064. Furthermore, if the delay is exclusively due to congestion (i.e. all links have $\ell_i(0) = 0$), then the bound can be improved to 3.125.*

We next consider instances of the game with convex, instead of concave, demand curves, while maintaining convex latencies. An example similar to the one above can be constructed to show that this game may still not have a Nash equilibrium. Unfortunately, unlike the game with concave demand curves, even when Nash equilibria do exist, we do not have any such bounds, as there exist examples with unbounded gap between the social utility of a Nash equilibrium and an optimal solution.

5. REFERENCES

- [1] D. Acemoglu and A. Ozdaglar. Competition and Efficiency in Congested Markets *Unpublished Manuscript*, 2004.
- [2] D. Acemoglu and A. Ozdaglar. Flow Control, Routing, and Performance from Service Provider Viewpoint. *Unpublished Manuscript*, 2004.
- [3] P. Afèche. Incentive-Compatible Revenue Management in Queuing Systems: Optimal Strategic Idleness and other Delaying Tactics. *Unpublished Manuscript*, 2004.
- [4] G. Allon and A. Federgruen. Competition in Service Industries. *Unpublished Manuscript*, 2004.

- [5] E. Anshelevich, A. Dasgupta, J. Kleinberg, É. Tardos, T. Wexler, and T. Roughgarden. The Price of Stability for Network Design with Fair Cost Allocation. *IEEE Symposium on Foundations of Computer Science*, 295–304, 2004.
- [6] E. Anshelevich, A. Dasgupta, É. Tardos, and T. Wexler. Near-Optimal Network Design with Selfish Agents. *ACM Symposium on Theory of Computing*, 511–520, 2003.
- [7] M. Beckmann, C. B. McGuire, and C. B. Winsten. *Studies in the Economics of Transportation*. Yale University Press, 1956.
- [8] R. Cole, Y. Dodis, and T. Roughgarden. Pricing Network Edges for Heterogeneous Selfish Users. *ACM Symposium on Theory of Computing*, 521–530, 2003.
- [9] R. Cole, Y. Dodis, and T. Roughgarden. How Much Can Taxes Help Selfish Routing. *ACM Conference on Electronic Commerce*, 98–107, 2003.
- [10] J. R. Correa, A. S. Schulz, and N. E. Stier-Moses. Selfish Routing in Capacitated Networks. *Mathematics of Operations Research*, 961–976, 2004.
- [11] A. Czumaj, P. Krysta and B. Vöcking. Selfish Traffic Allocation for Server Farms. *ACM Symposium on Theory of Computing*, 287–296, 2002.
- [12] A. Czumaj and B. Vöcking. Tight Bounds for Worst-Case Equilibria. *ACM-SIAM Symposium on Discrete Algorithms*, 413–420, 2002.
- [13] A. Fabrikant, A. Luthra, E. Maneva, C. H. Papadimitriou, and S. Shenker. On a Network Creation Game. *ACM SIGACT-SIGOPT Symposium on Principles of Distributed Computing*, 247–251, 2003.
- [14] L. Fleischer, K. Jain, and M. Mahdian. Tolls for Heterogeneous Selfish Users in Multicommodity Networks and Generalized Congestion Games. *IEEE Symposium on Foundations of Computer Science*, 277–285, 2004.
- [15] G. Karakostas and S. G. Kolliopoulos. Edge Pricing of Multicommodity Networks for Heterogeneous Selfish Users. *IEEE Symposium on Foundations of Computer Science*, 268–276, 2004.
- [16] E. Koutsoupias and C. H. Papadimitriou. Worst-Case Equilibria. *International Symposium on Theoretical Aspects of Computer Science*, 404–413, 1999.
- [17] I.H. Lee and R. Mason. Market Structure in Congestible Markets. *European Economic Review*, 45 (4-6), 809–818, 2001.
- [18] A. C. Pigou. *The Economics of Welfare*. Macmillan and Co., 1920.
- [19] T. Roughgarden. The Price of Anarchy is Independent of the Network Topology. *ACM Symposium on Theory of Computing*, 428–437, 2002.
- [20] T. Roughgarden. Stackelberg Scheduling Strategies. *ACM Symposium on Theory of Computing*, 104–113, 2001.
- [21] T. Roughgarden and É. Tardos. How Bad Is Selfish Routing? *IEEE Symposium on Foundations of Computer Science*, 93–102, 2000.
- [22] S. Suri, C. D. Toth, and Y. Zhou. Selfish Load Balancing and Atomic Congestion Games. *ACM Symposium on Parallel Algorithms and Architectures*, 188–195, 2004.
- [23] A. Vetta. Nash Equilibria in Competitive Societies, with Applications to Facility Location, Traffic Routing and Auctions. *IEEE Symposium on Foundations of Computer Science*, 416–425, 2002.