

CS 4410
Operating Systems

Review (2)

Summer 2016
Cornell University

Organization of files

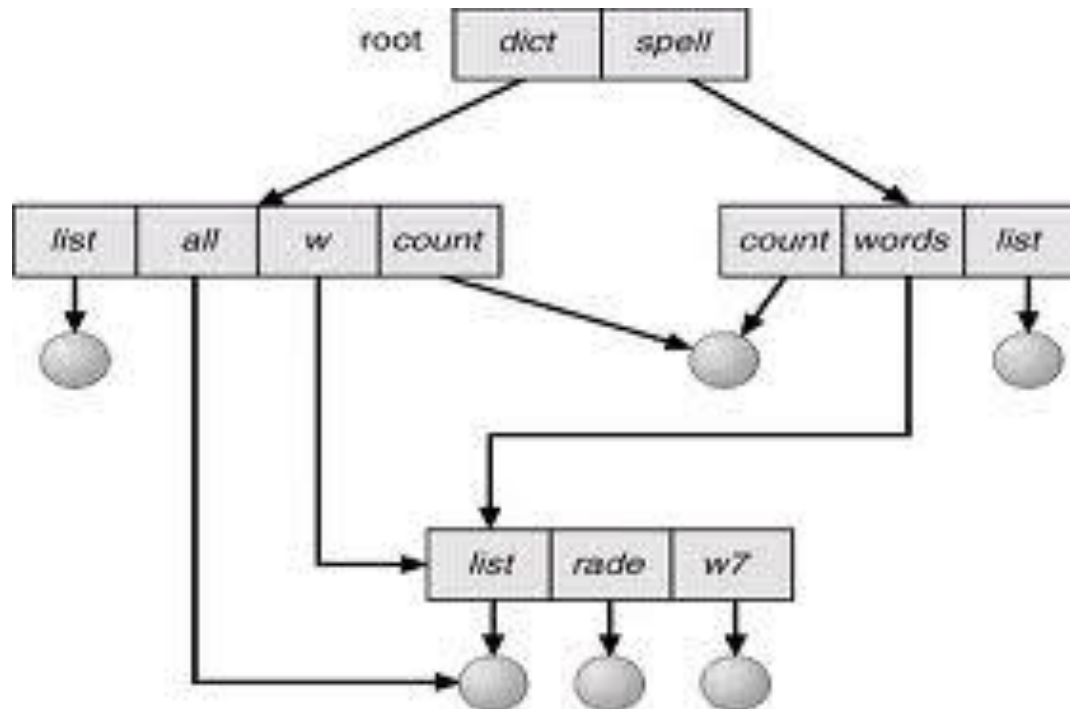

Disk Scheduling

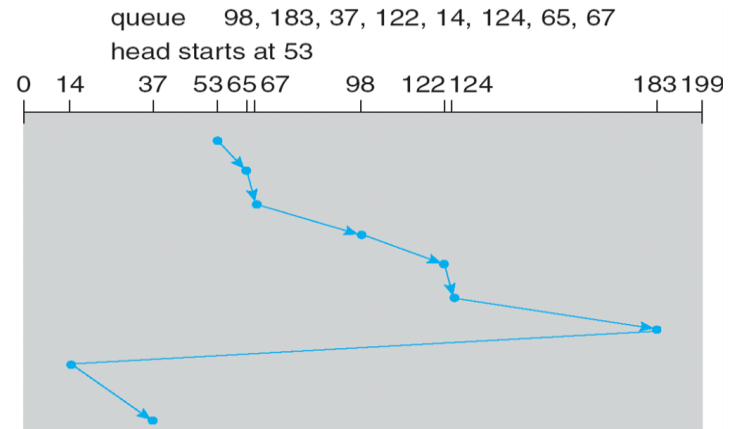
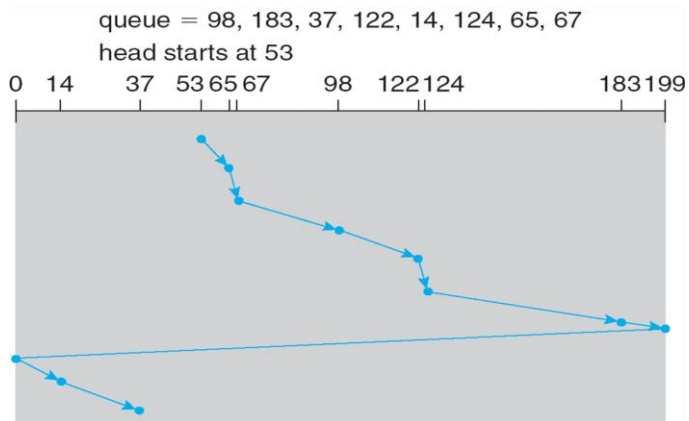
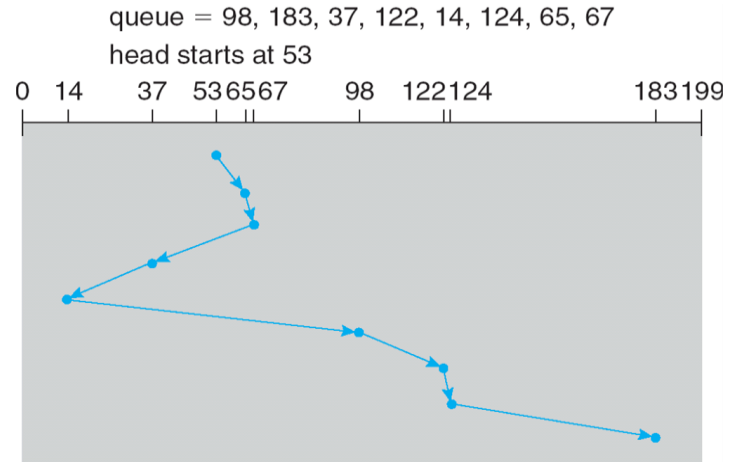
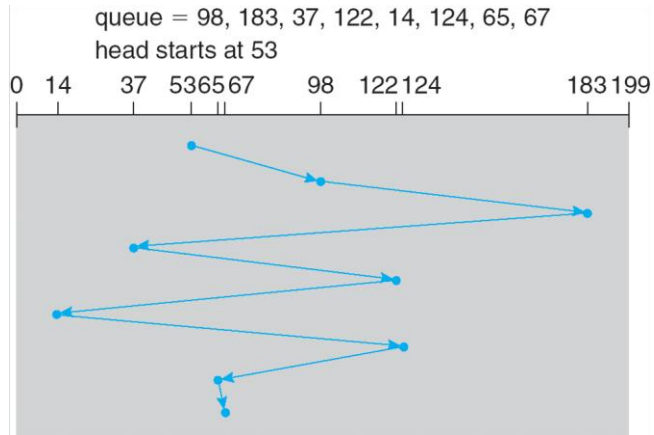

RAID

- By striping files across multiple disks (placing parts of each file on a different disk), parallel I/O can improve access time.
- Improve reliability with redundancy.

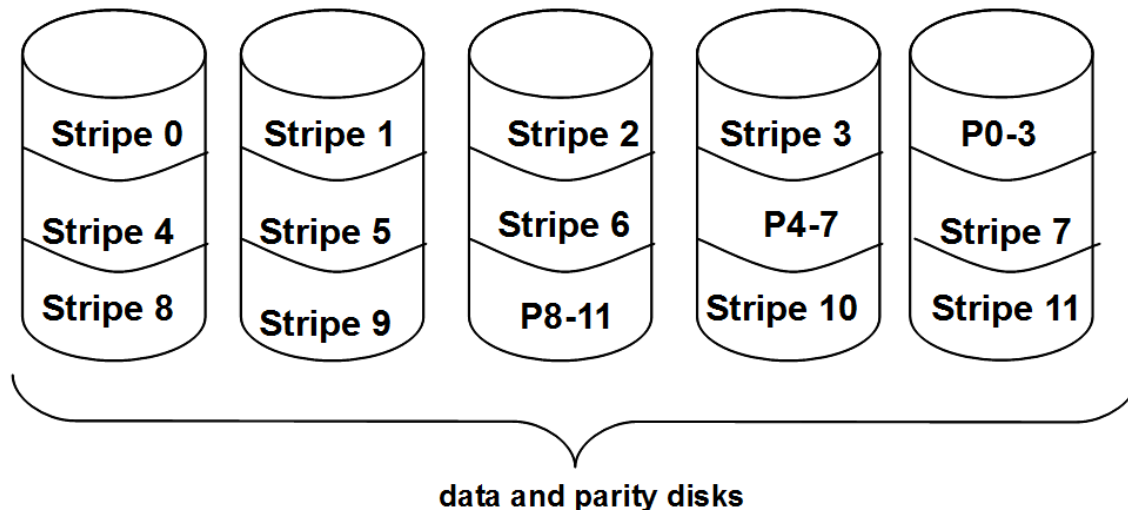

File System Implementation

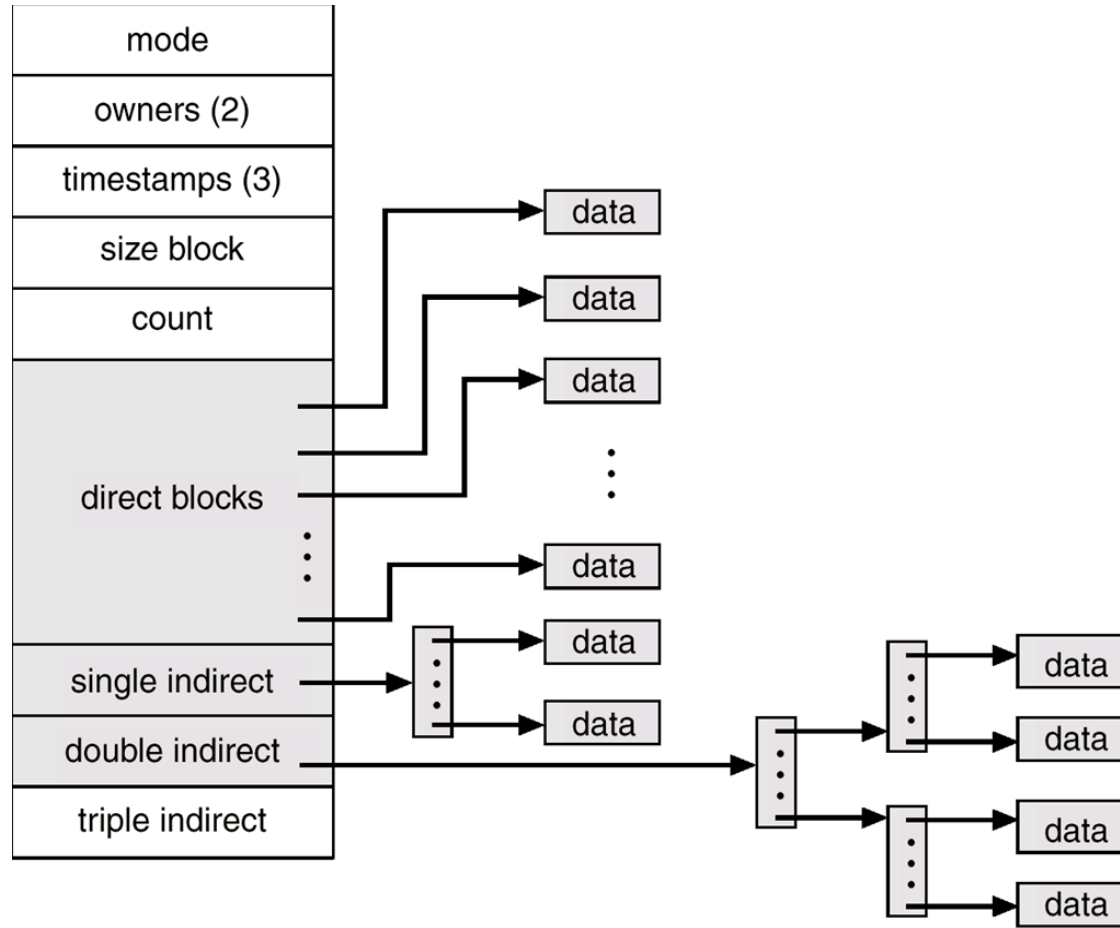

Network protocol

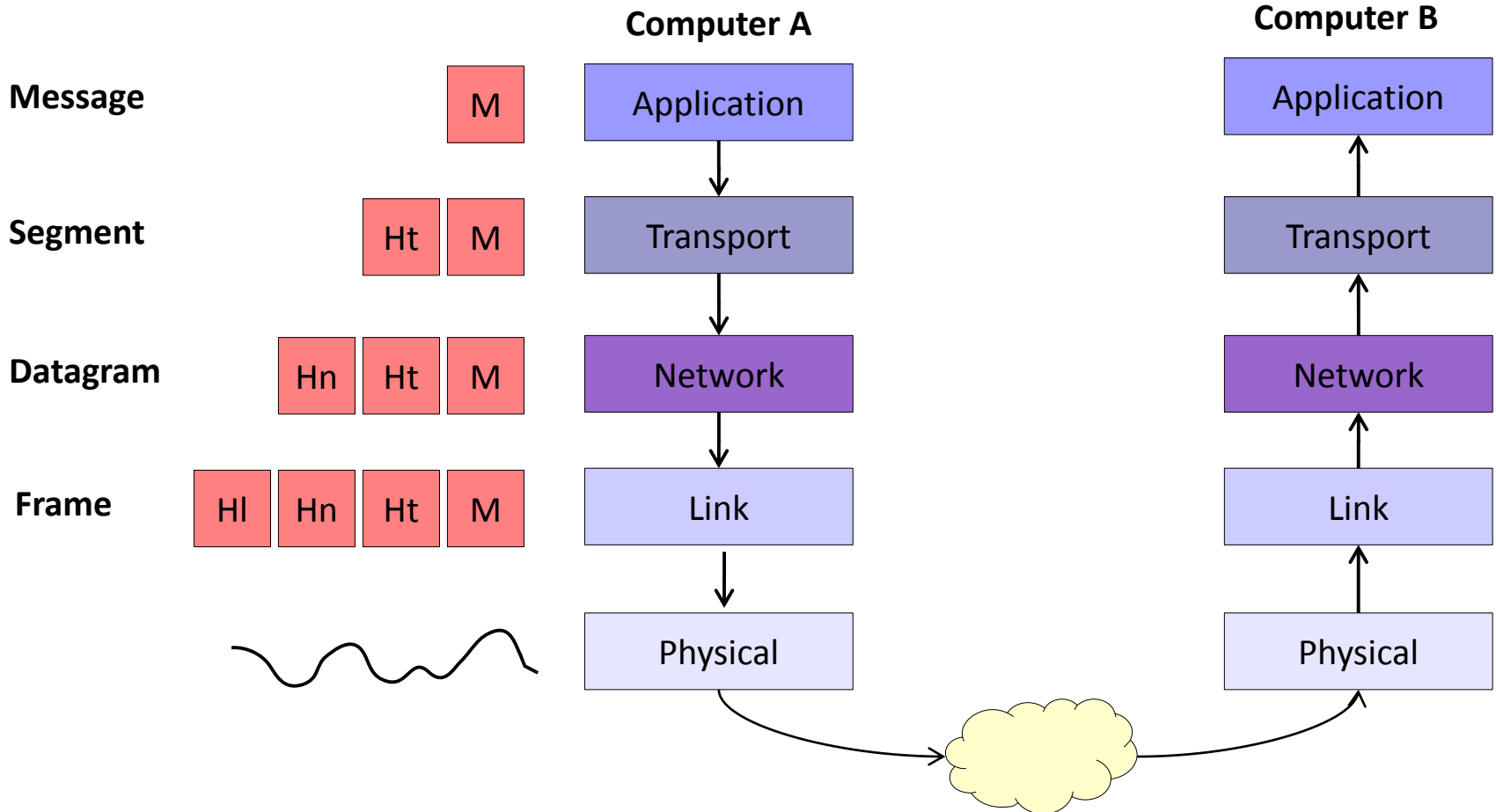

Security

- Security policies are typically formulated in terms of the three basic kinds of *security properties*:
 - **Confidentiality**. Which principals are allowed to learn what information.
 - **Integrity**. What changes to the system (stored information and resource usage) and to its environment (outputs) are allowed.
 - **Availability**. When must inputs be read or outputs produced.