

# Prelim 3 Review

**Hakim Weatherspoon**

**CS 3410, Spring 2012**

Computer Science

Cornell University

# Administrivia

---

## Pizza party: PA3 Games Night

- Tomorrow, Friday, April 27<sup>th</sup>, 5:00-7:00pm
- Location: Upson B17

## Prelim 3

- Tonight, Thursday, April 26<sup>th</sup>, 7:30pm
- Location: Olin 155

## PA4: Final project out next week

- Demos: May 14-16
- ***Will not be able to use slip days***

# Goals for Today

---

## Prelim 3 review

- Caching,
- Virtual Memory, Paging, TLBs
- Operating System, Traps, Exceptions,
- Multicore and synchronization

# Big Picture

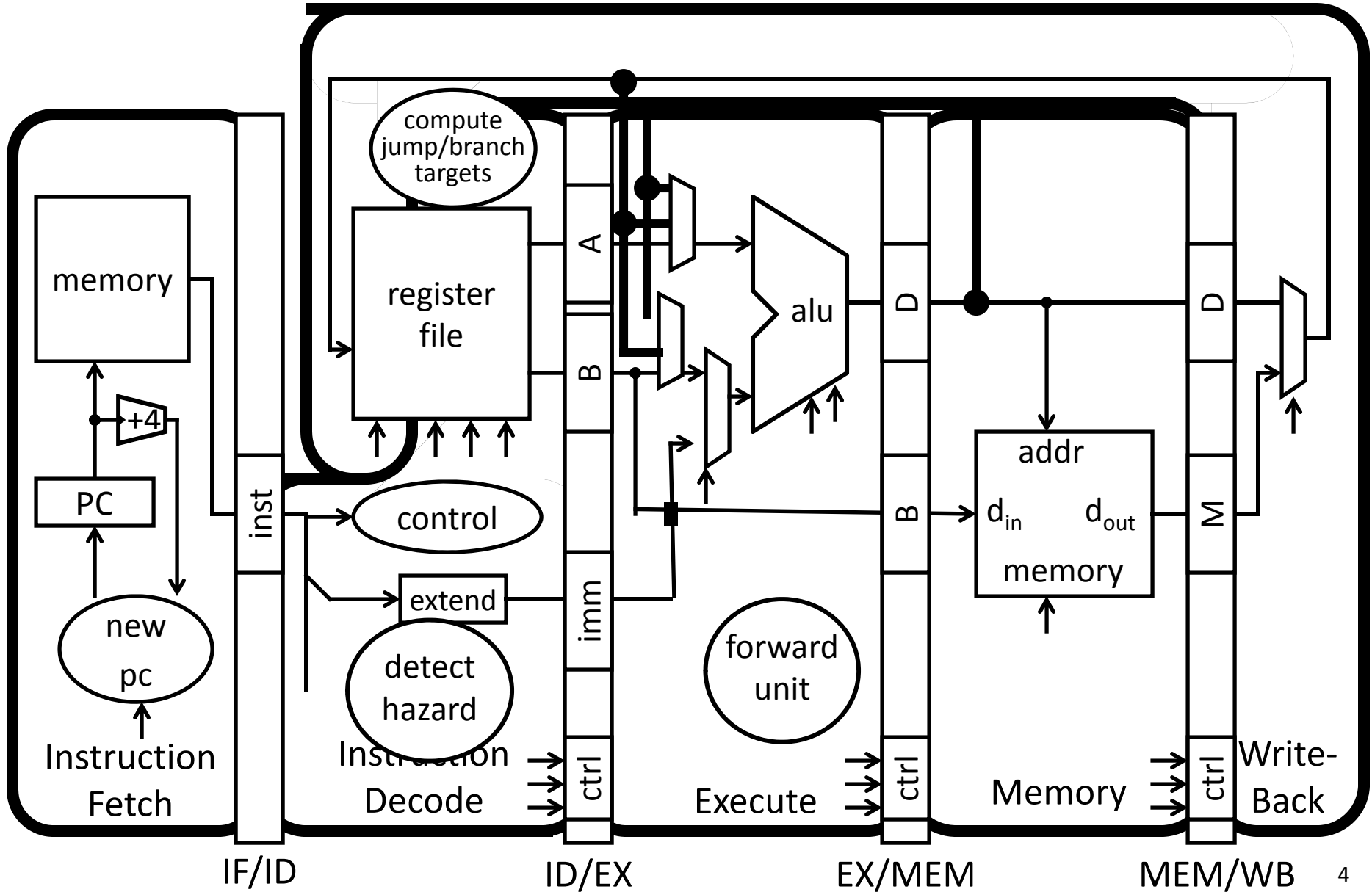

---

# Memory Hierarchy and Caches

# Memory Pyramid

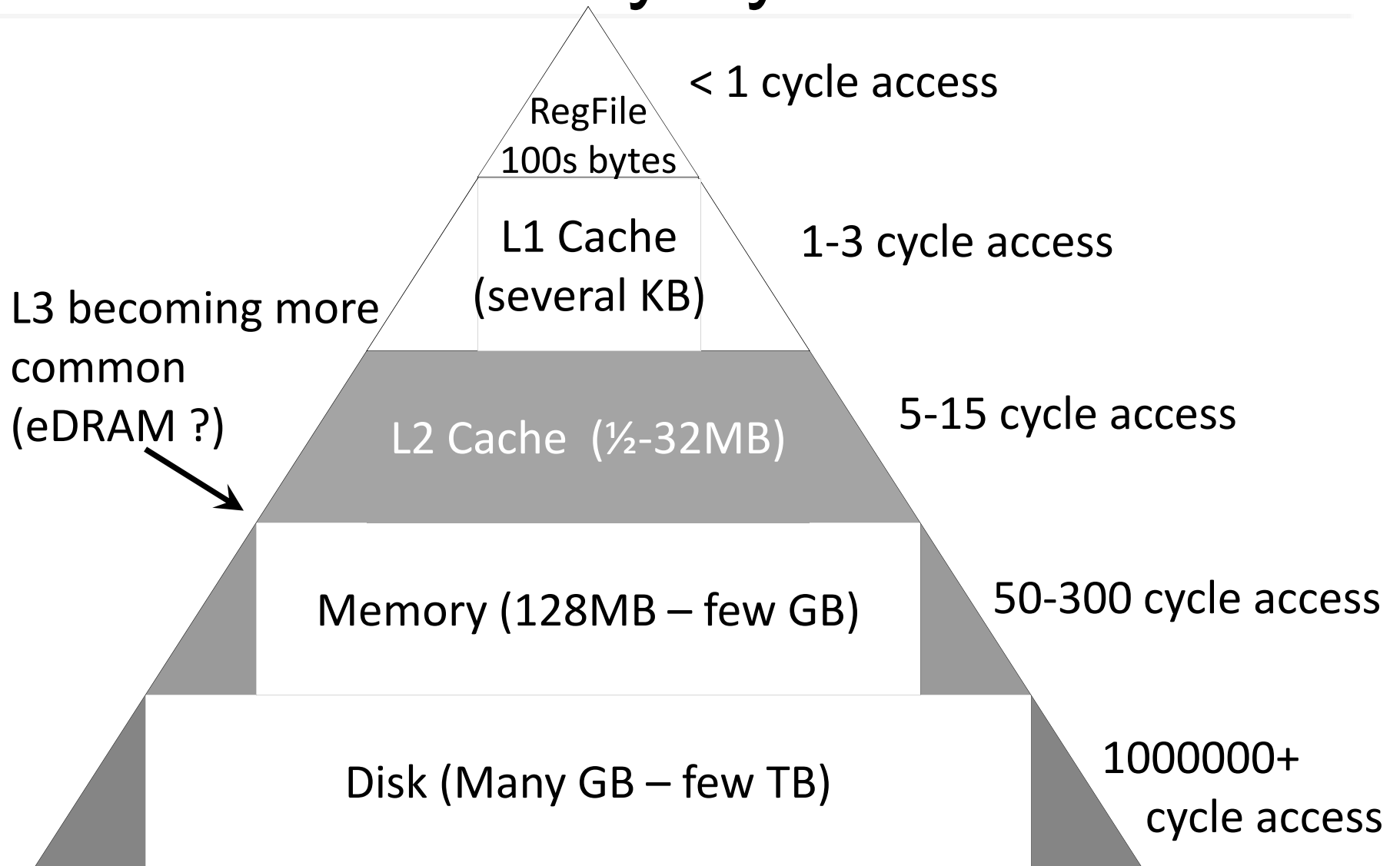

These are rough numbers: mileage may vary for latest/greatest  
Caches usually made of SRAM (or eDRAM)

# Memory Hierarchy

---

## Insight for Caches

If Mem[x] is was accessed *recently*...

... then Mem[x] is likely to be accessed *soon*

- Exploit temporal locality:
  - Put recently accessed Mem[x] higher in memory hierarchy since it will likely be accessed again soon

... then Mem[x  $\pm \epsilon$ ] is likely to be accessed *soon*

- Exploit spatial locality:
  - Put entire block containing Mem[x] and surrounding addresses higher in memory hierarchy since nearby address will likely be accessed

# Memory Hierarchy

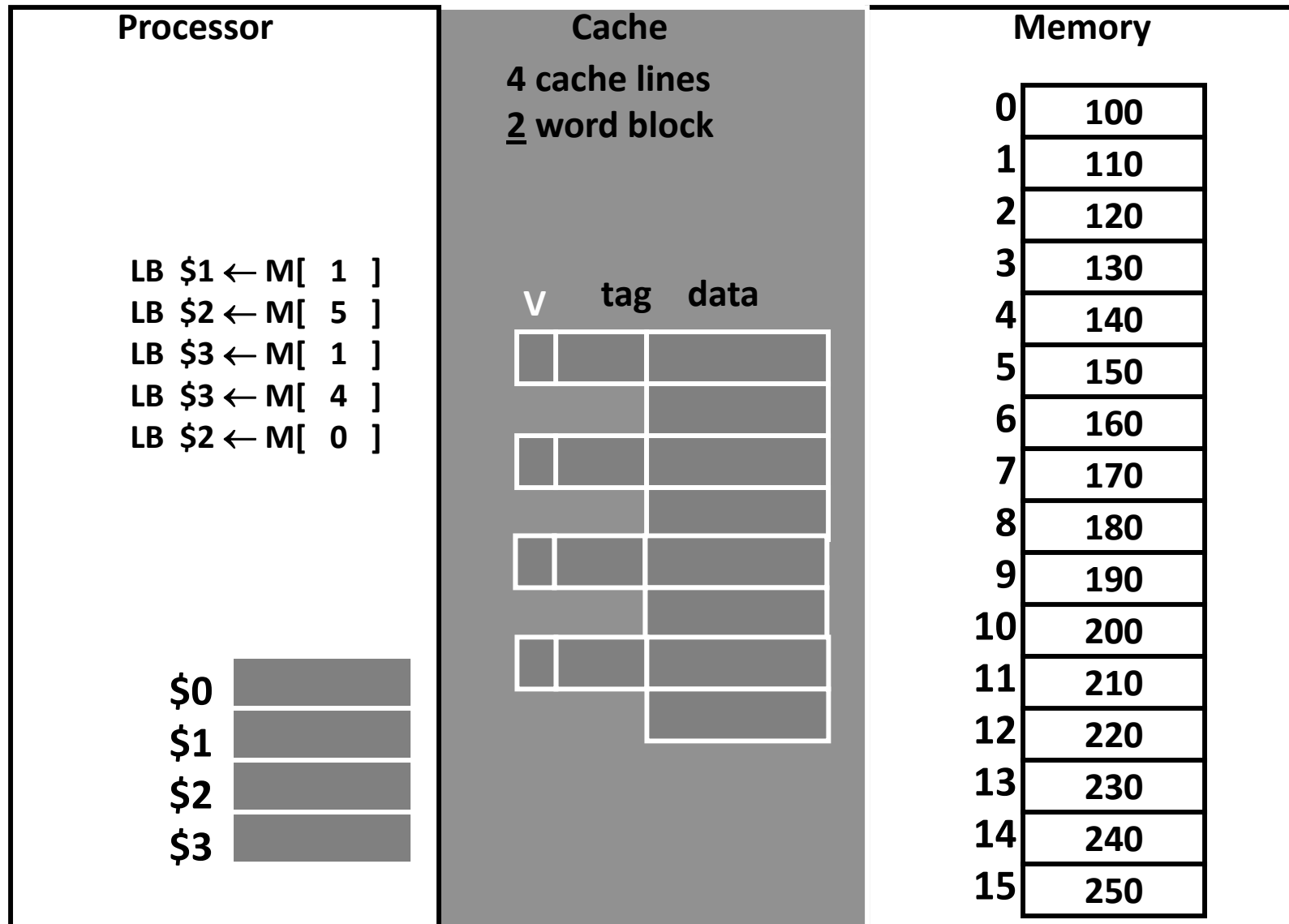



# Three Common Cache Designs

---

A given data block can be placed...

- ... in exactly one cache line → Direct Mapped
- ... in any cache line → Fully Associative
- ... in a small set of cache lines → Set Associative

# Direct Mapped Cache

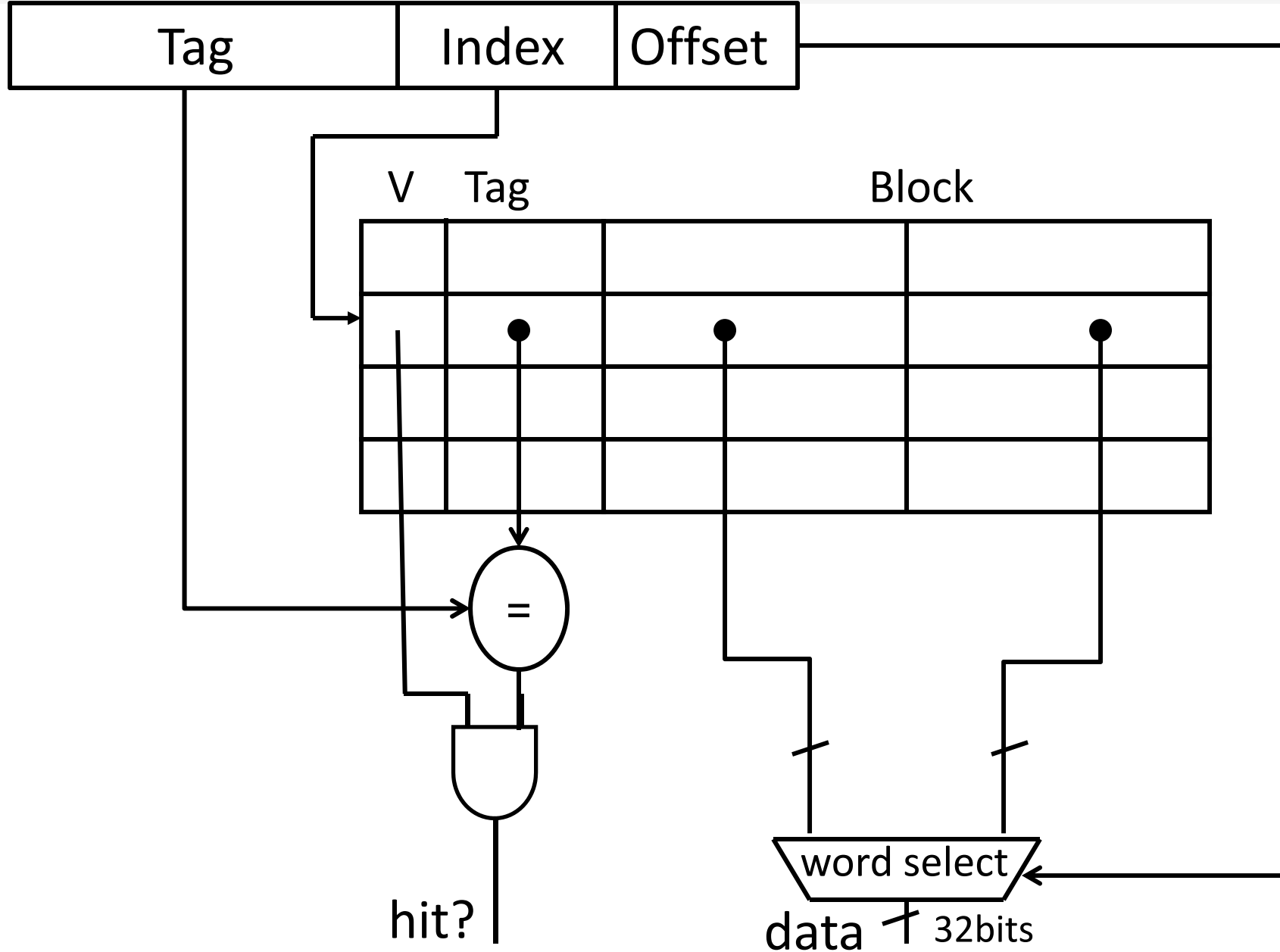

# Fully Associative Cache

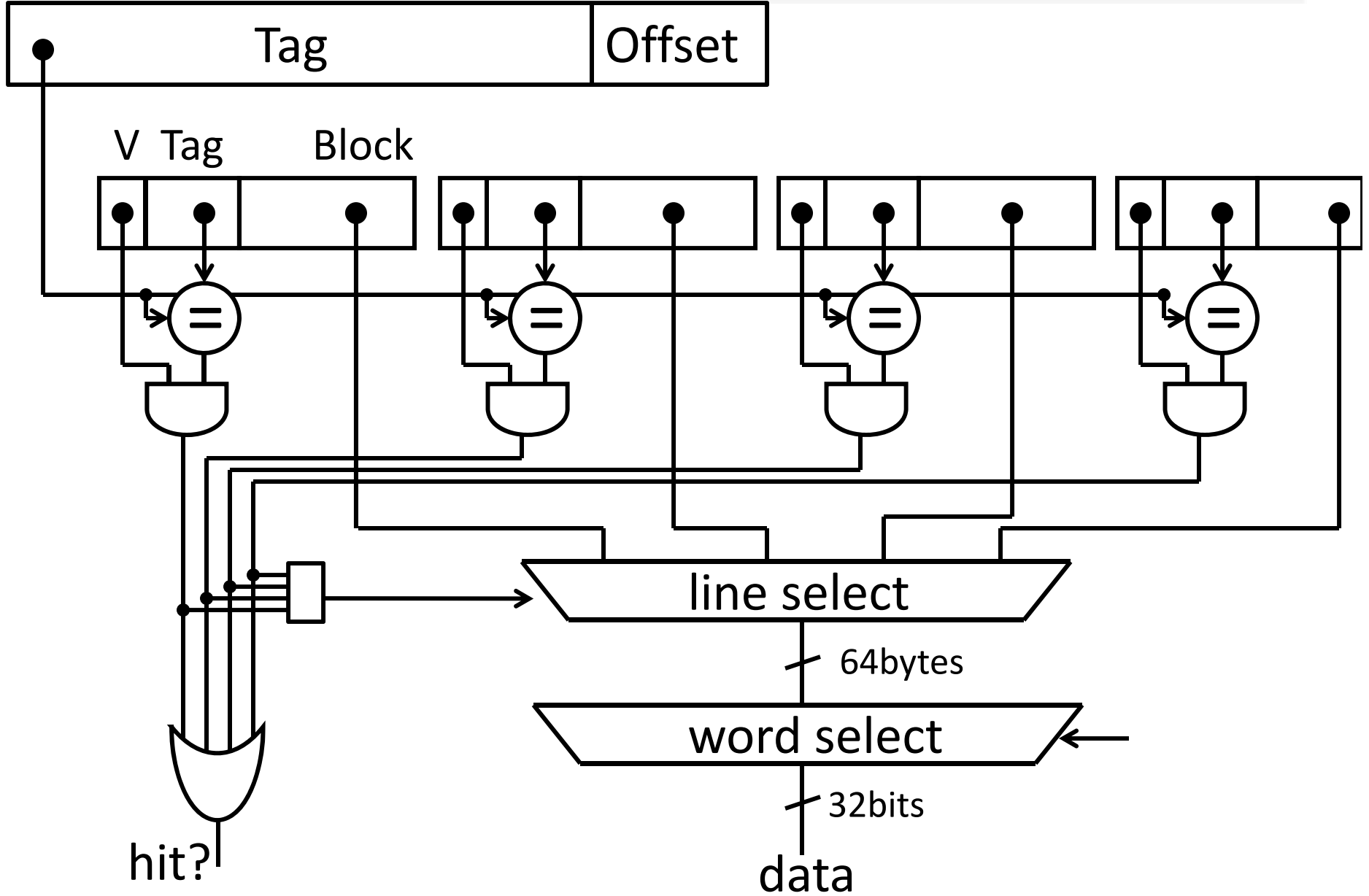

# 3-Way Set Associative Cache

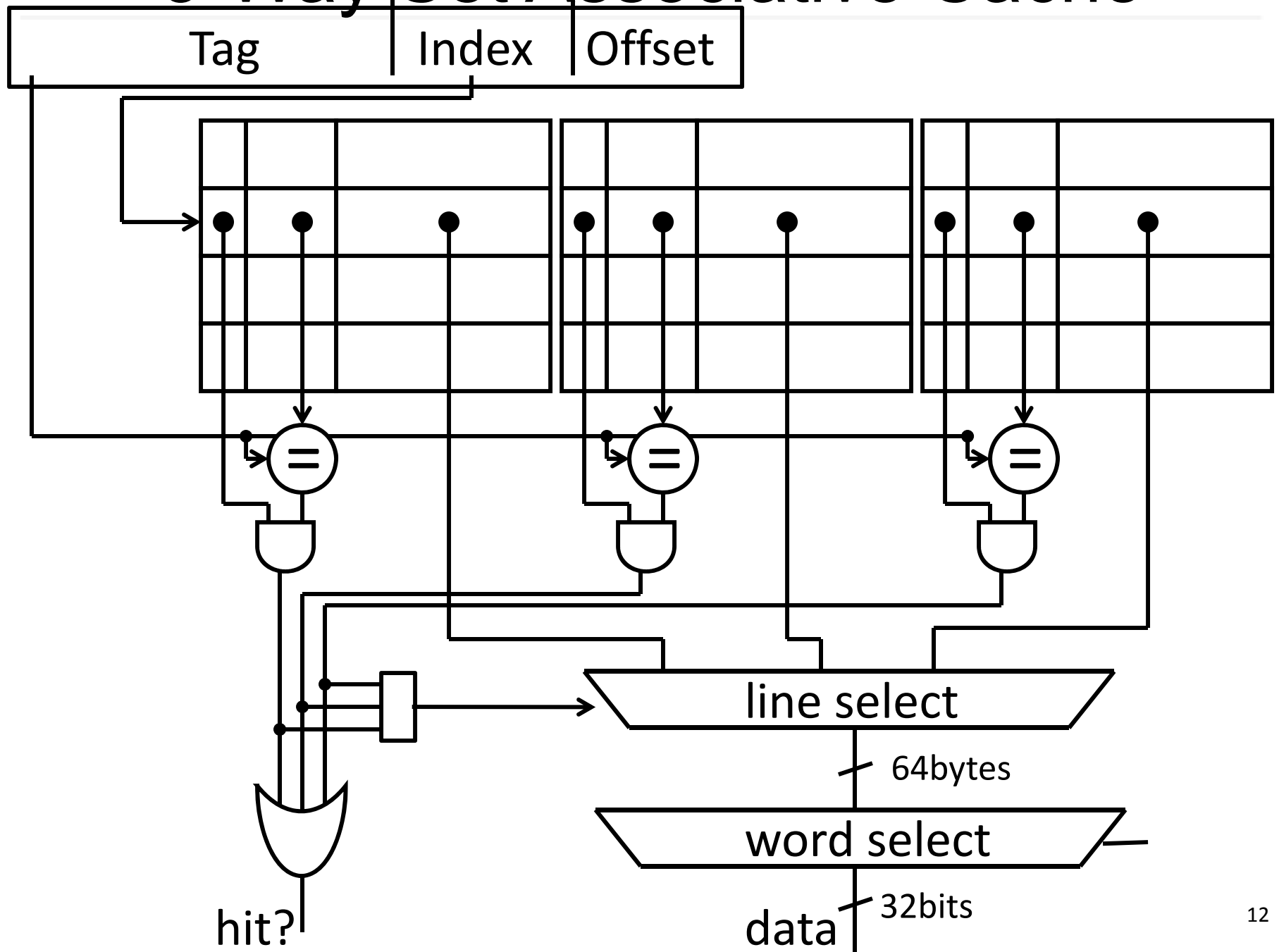

# Cache *Misses*

---

- Three types of misses
  - Cold (aka Compulsory)
    - The line is being referenced for the first time
  - Capacity
    - The line was evicted because the cache was not large enough
  - Conflict
    - The line was evicted because of another access whose index conflicted

---

# Writing with Caches

# Eviction

---

Which cache line should be evicted from the cache to make room for a new line?

- Direct-mapped
  - no choice, must evict line selected by index
- Associative caches
  - random: select one of the lines at random
  - round-robin: similar to random
  - FIFO: replace oldest line
  - LRU: replace line that has not been used in the longest time

# Cached Write Policies

Q: How to write data?

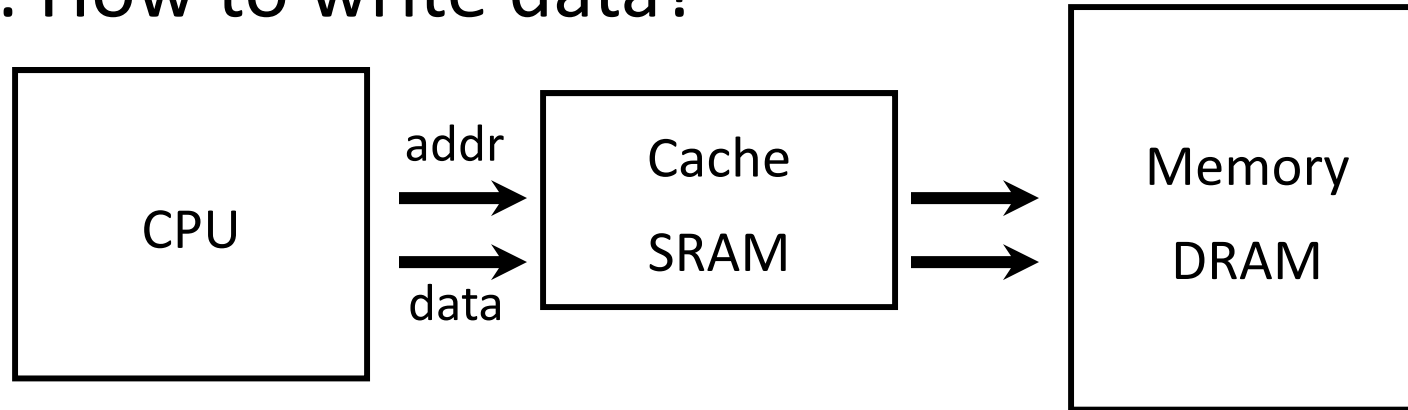

If data is already in the cache...

No-Write

- writes invalidate the cache and go directly to memory

Write-Through

- writes go to main memory and cache

Write-Back

- CPU writes only to cache
- cache writes to main memory later (when block is evicted)



# What about Stores?

Where should you write the result of a store?

- If that memory location is in the cache?
  - Send it to the cache
  - Should we also send it to memory right away?  
(write-through policy)
  - Wait until we kick the block out (write-back policy)
- If it is not in the cache?
  - Allocate the line (put it in the cache)?  
(write allocate policy)
  - Write it directly to memory without allocation?  
(no write allocate policy)

---

# Cache Performance

# Cache Performance

---

- Consider hit (H) and miss ratio (M)
- $H \times AT_{\text{cache}} + M \times AT_{\text{memory}}$
- Hit rate = 1 – Miss rate
- Access Time is given in cycles
- Ratio of Access times, 1:50
  
- 90% :  $.90 + .1 \times 50 = 5.9$
- 95% :  $.95 + .05 \times 50 = .95 + 2.5 = 3.45$
- 99% :  $.99 + .01 \times 50 = 1.49$
- 99.9%:  $.999 + .001 \times 50 = 0.999 + 0.05 = 1.049$

---

# Cache Conscious Programming

# Cache Conscious Programming

```
// H = 12, NCOL = 10  
int A[NROW][NCOL];  
  
for(col=0; col < NCOL; col++)  
    for(row=0; row < NROW; row++)  
        sum += A[row][col];
```

1	11	21							
		2	12	22					
				3	13	23			
						4	14	24	
								5	15
									25
6	16	26							
		7	17	...					
				8	18				
						9	19		
								10	20

Every access is a cache miss!

(unless *entire* matrix can fit in cache)

# Cache Conscious Programming

```
// NROW = 12, NCOL = 10
```

```
int A[NROW][NCOL];
```

```
for(row=0; row < NROW; row++)
```

```
    for(col=0; col < NCOL; col++)
```

```
        sum += A[row][col];
```

1	2	3	4	5	6	7	8	9	10
11	12	13	...						

Block size = 4 → 75% hit rate

Block size = 8 → 87.5% hit rate

Block size = 16 → 93.75% hit rate

And you can easily prefetch to warm the cache.

- 
- MMU, Virtual Memory, Paging, and TLB's

# Multiple Processes

Q: What happens when another program is executed concurrently on another processor?

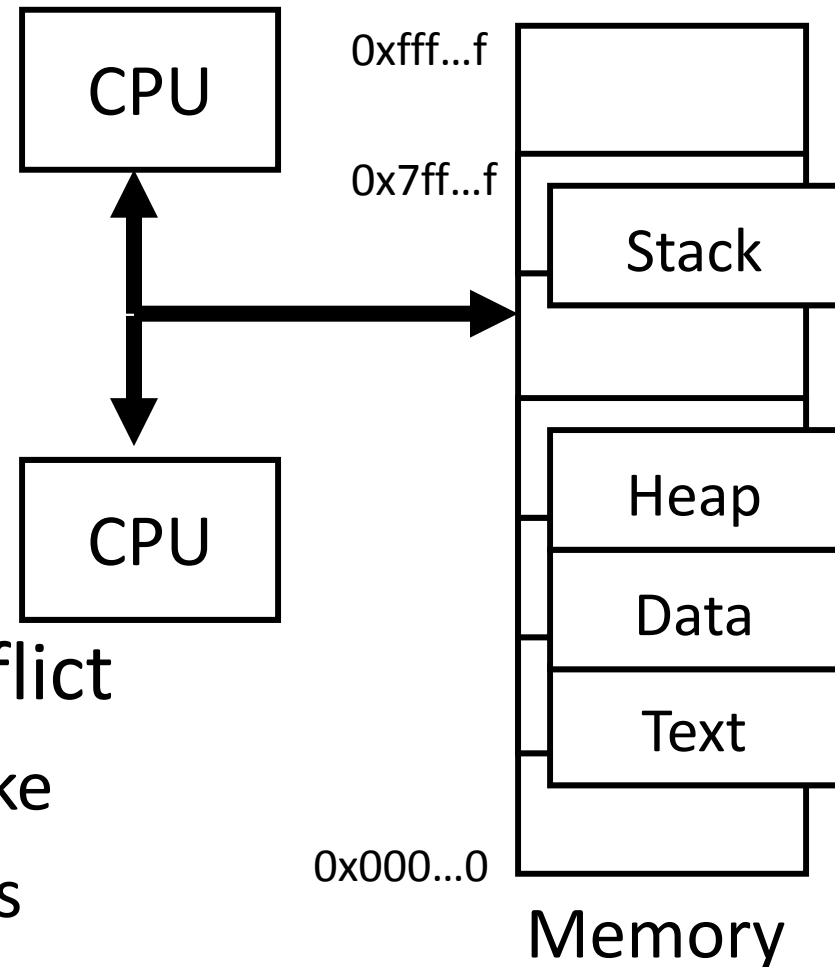

A: The addresses will conflict

- Even though, CPUs may take turns using memory bus



# Virtual Memory

---

## Virtual Memory: A Solution for All Problems

Each process has its own virtual address space

- Programmer can code as if they own all of memory

On-the-fly at runtime, for each memory access

- all access is *indirect* through a virtual address
- translate fake virtual address to a real physical address
- redirect load/store to the physical address

# Virtual Memory Advantages

## Advantages

### Easy relocation

- Loader puts code anywhere in physical memory
- Creates virtual mappings to give illusion of correct layout

### Higher memory utilization

- Provide illusion of contiguous memory
- Use all physical memory, even physical address 0x0

### Easy sharing

- Different mappings for different programs / cores

### Different Permissions bits

# Address Space

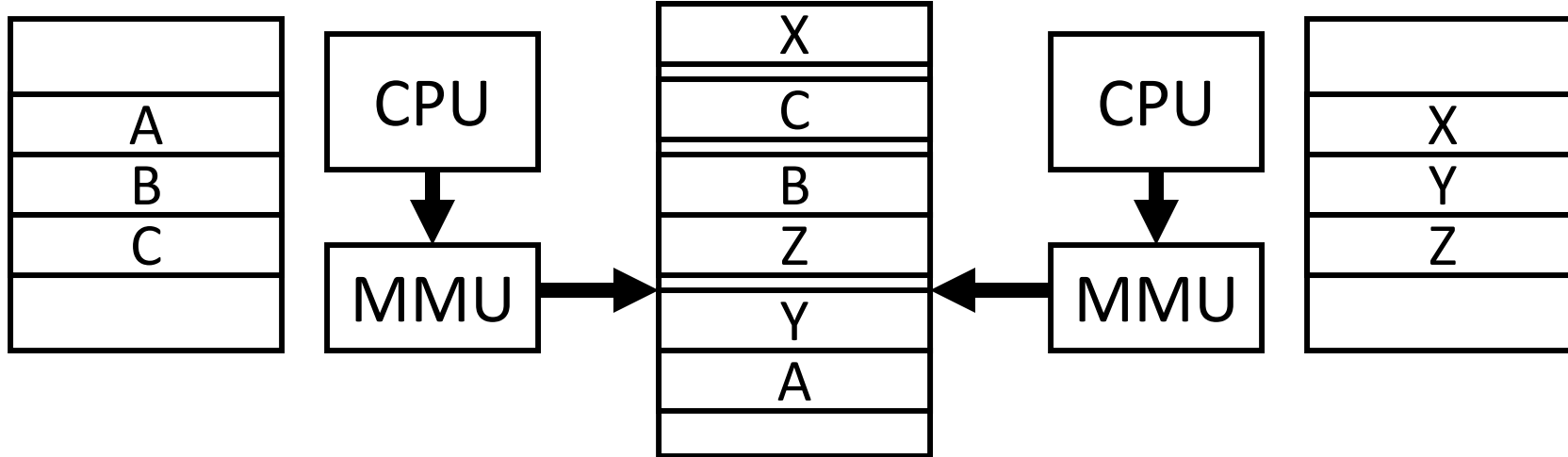

Programs load/store to virtual addresses

Actual memory uses physical addresses

Memory Management Unit (MMU)

- Responsible for translating on the fly
- Essentially, just a big array of integers:  
`paddr = PageTable[vaddr];`

# Address Translation

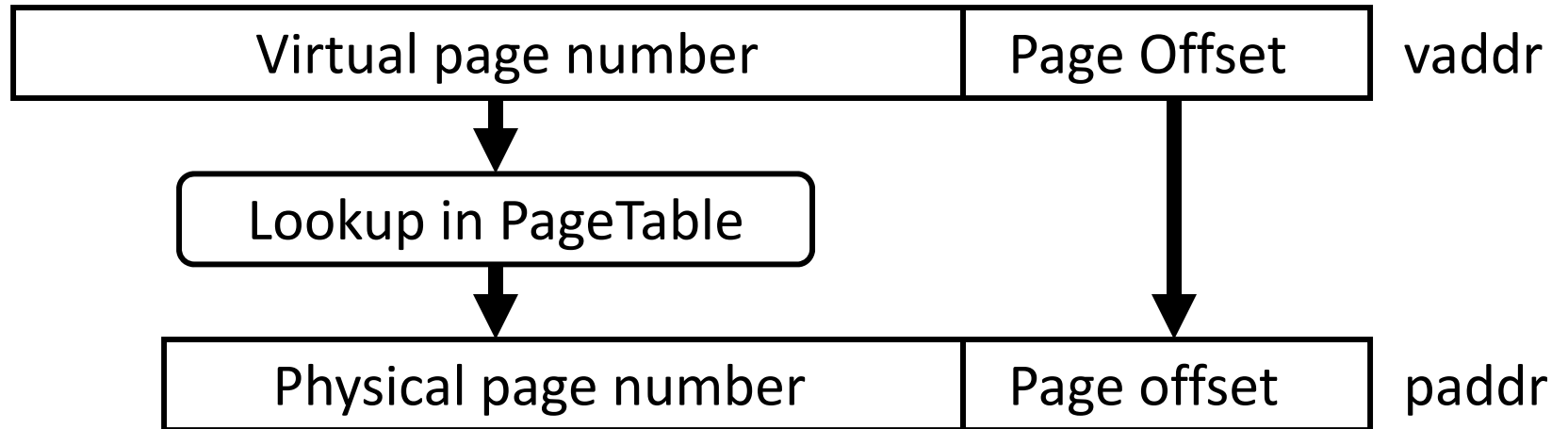

**Attempt #1:** For any access to virtual address:

- Calculate virtual page number and page offset
- Lookup physical page number at `PageTable[vpn]`
- Calculate physical address as `ppn:offset`

# Beyond Flat Page Tables

Assume most of PageTable is empty

How to translate addresses? Multi-level PageTable

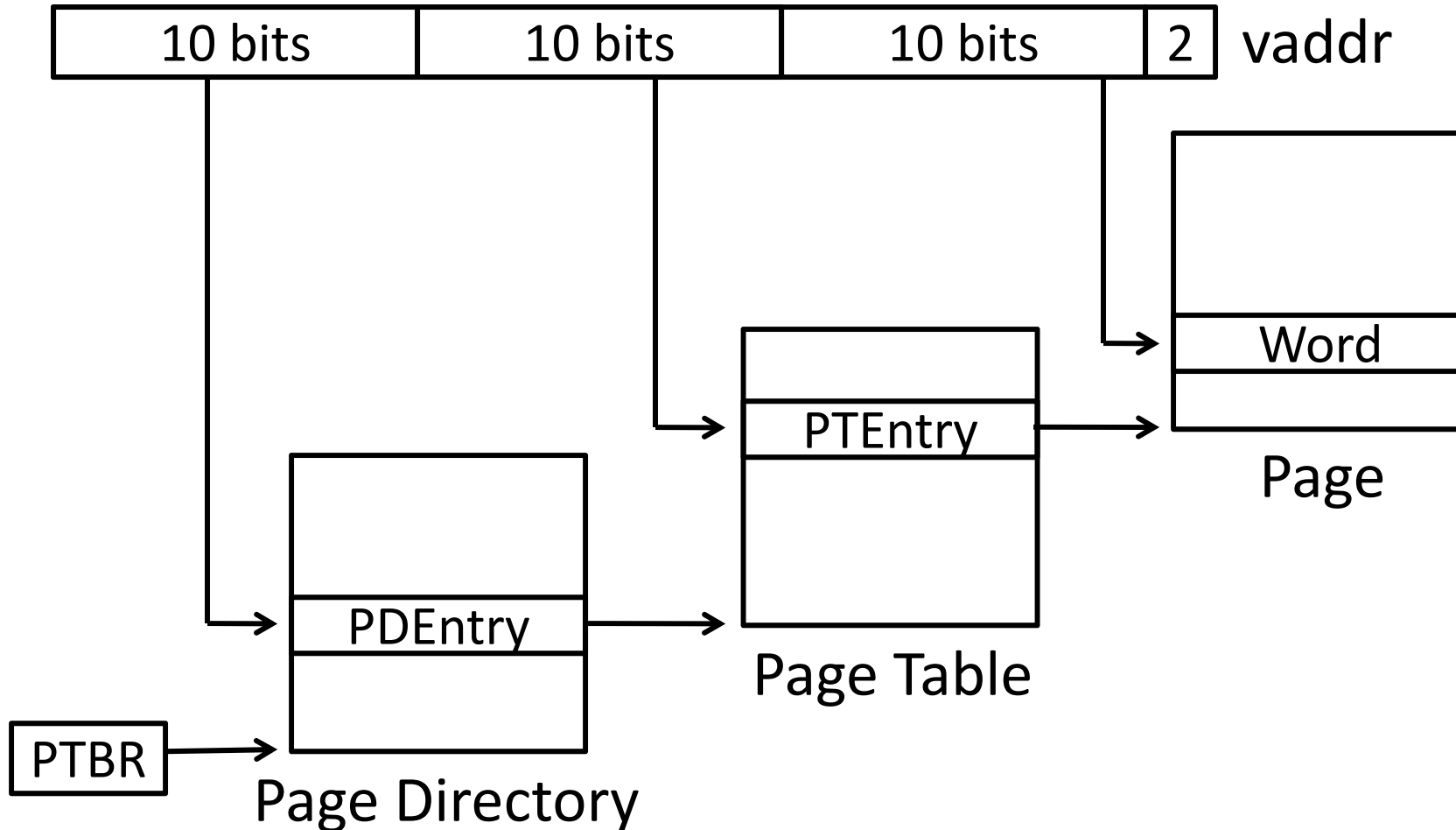

\* x86 does exactly this

# Virtual Addressing with a Cache

---

- Thus it takes an *extra* memory access to translate a VA to a PA

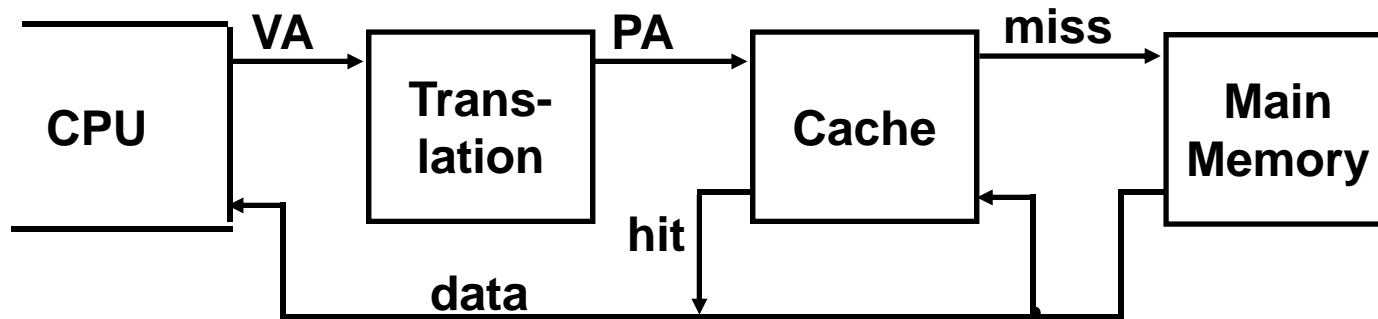

- This makes memory (cache) accesses very expensive (if every access was really *two* accesses)

# A TLB in the Memory Hierarchy

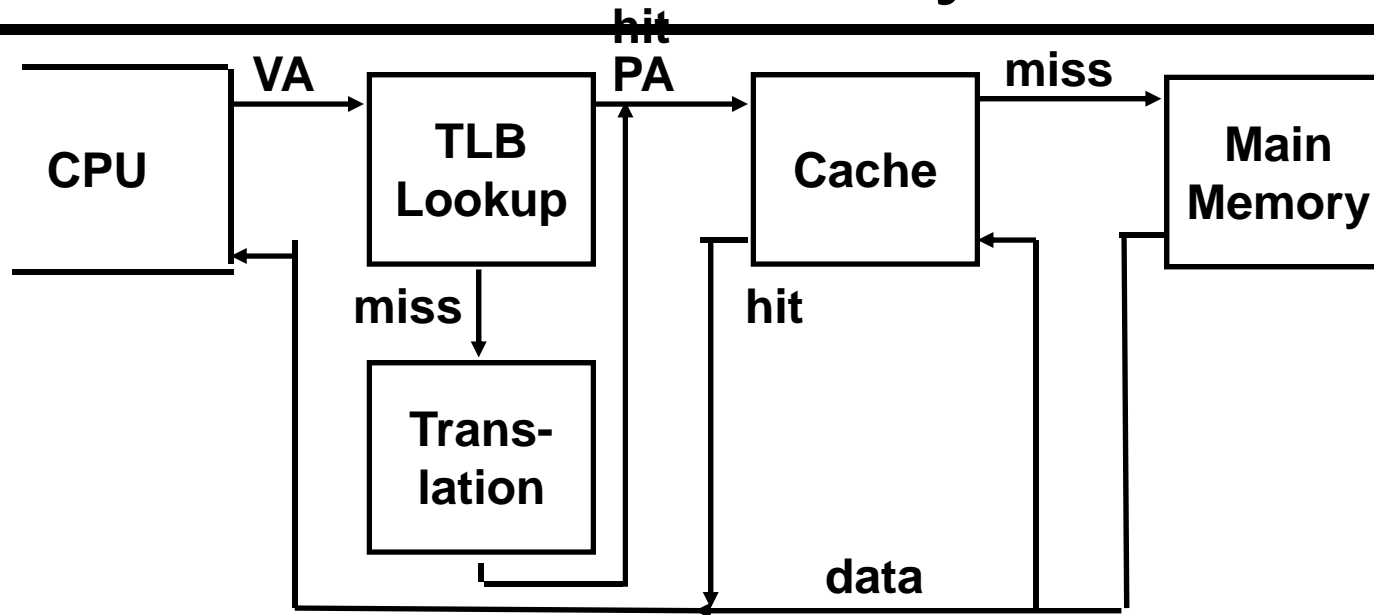

- A TLB miss:
  - If the page is not in main memory, then it's a true page fault
    - Takes 1,000,000's of cycles to service a page fault
- TLB misses are much more frequent than true page faults

# Virtual vs. Physical Caches

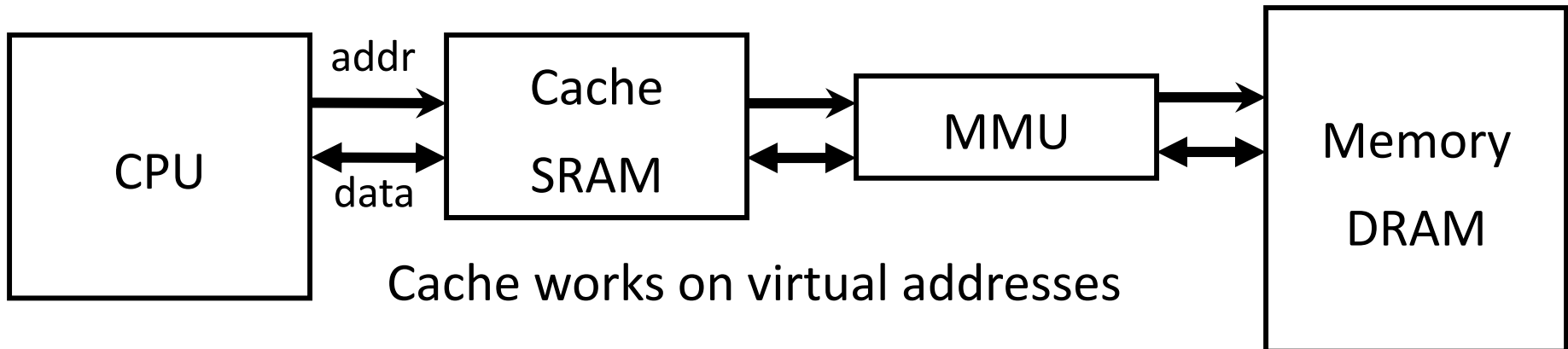
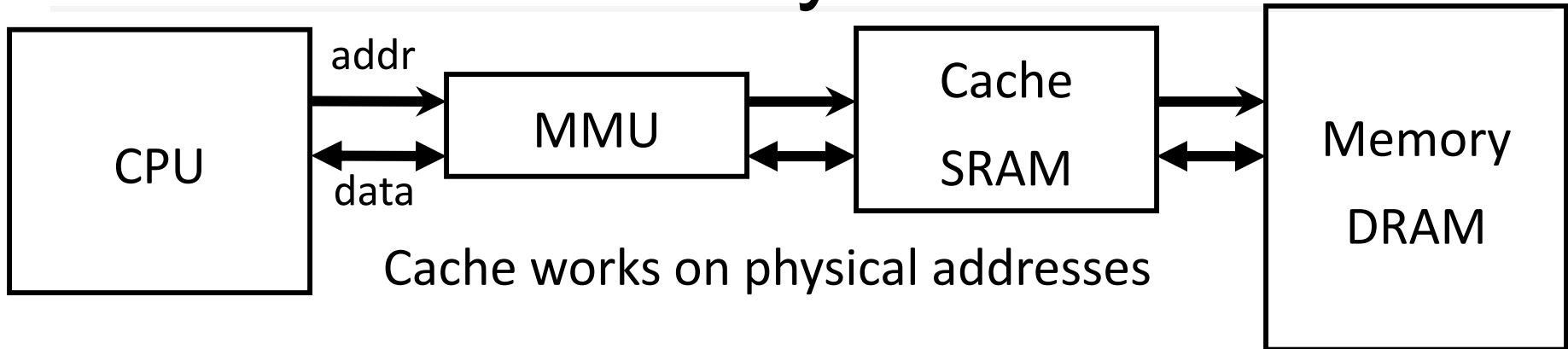

Q: What happens on context switch?

Q: What about virtual memory aliasing?

Q: So what's wrong with physically addressed caches?



# Indexing vs. Tagging

## Physically-Addressed Cache

- slow: requires TLB (and maybe PageTable) lookup first

## Virtually-Addressed Cache

- fast: start TLB lookup before cache lookup finishes
- PageTable changes (paging, context switch, etc.)
  - need to purge stale cache lines (how?)
- Synonyms (two virtual mappings for one physical page)
  - could end up in cache twice (very bad!)

## Virtually-Indexed, Physically Tagged Cache

- ~fast: TLB lookup in parallel with cache lookup
- PageTable changes → no problem: phys. tag mismatch
- Synonyms → search and evict lines with same phys. tag

# Indexing vs. Tagging

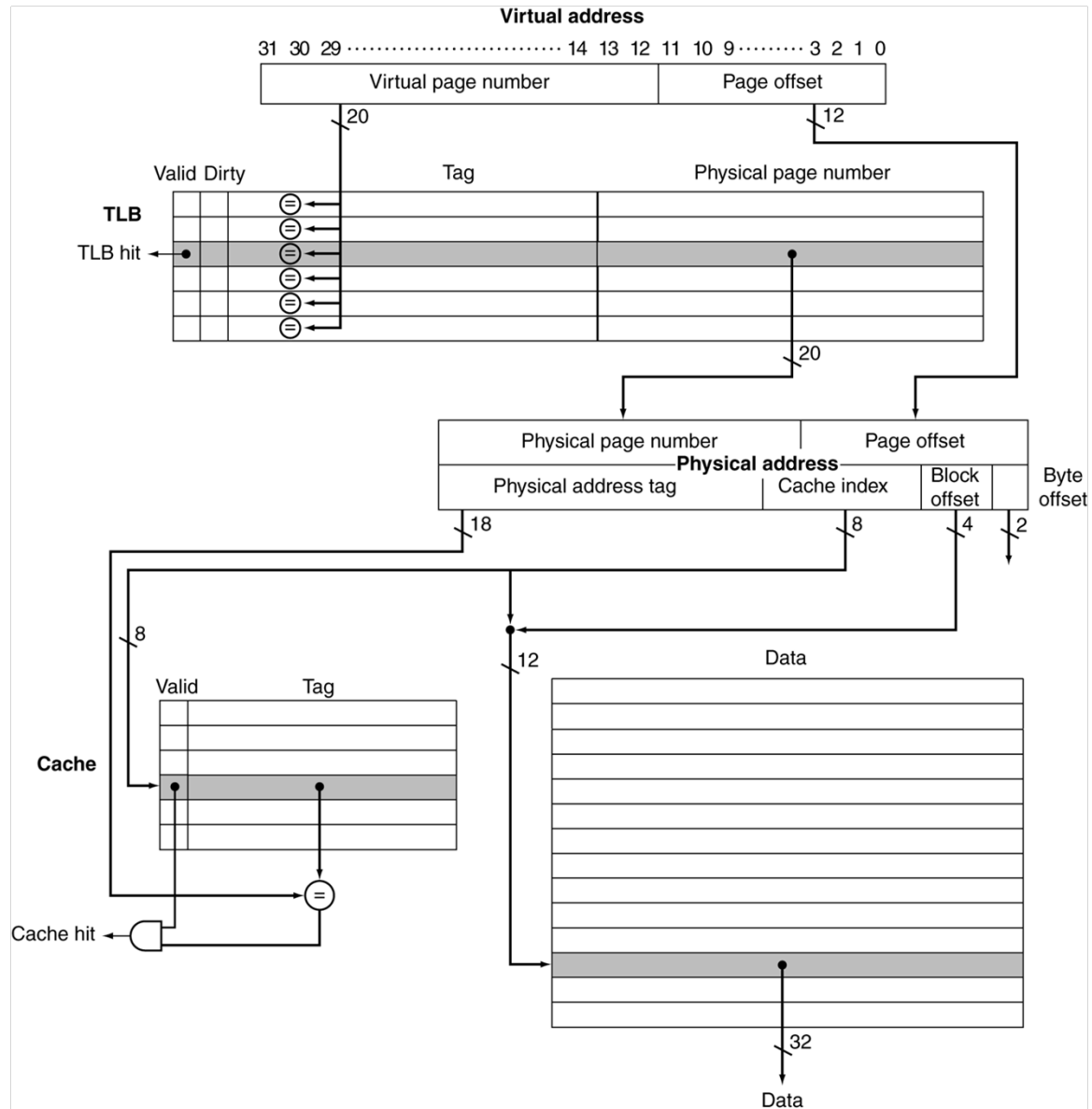

# Typical Cache Setup

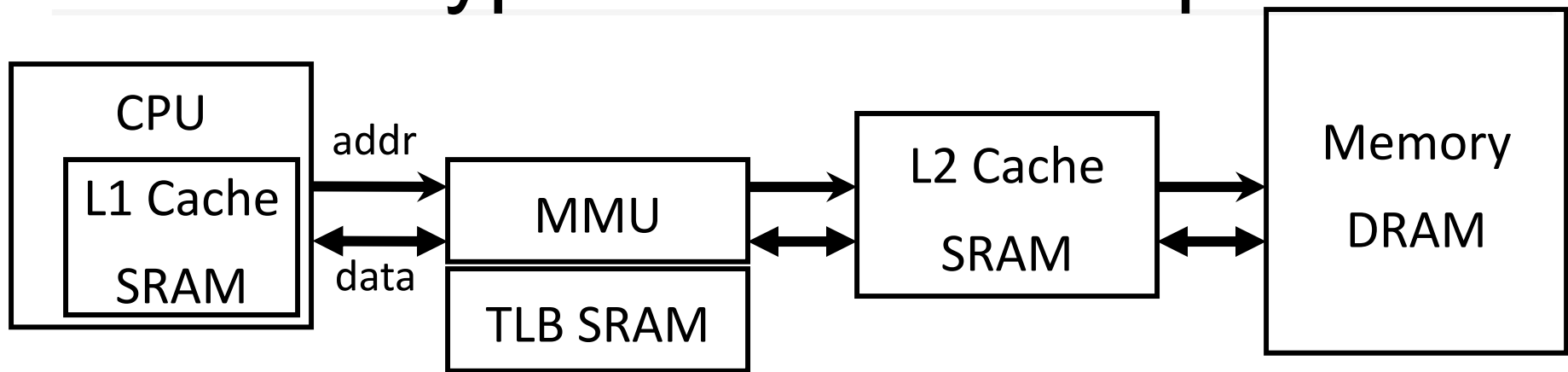

Typical L1: On-chip virtually addressed, physically tagged

Typical L2: On-chip physically addressed

Typical L3: On-chip ...

---

# Hardware/Software Boundary

# Hardware/Software Boundary

---

- Virtual to physical address translation is assisted by hardware?
  - Translation Lookaside Buffer (TLB) that caches the recent translations
    - TLB access time is part of the cache hit time
    - May allot an extra stage in the pipeline for TLB access
  - TLB miss
    - Can be in software (kernel handler) or hardware

# Hardware/Software Boundary

---

- Virtual to physical address translation is assisted by hardware?
  - Page table storage, fault detection and updating
    - Page faults result in interrupts (precise) that are then handled by the OS
    - Hardware must support (i.e., update appropriately) Dirty and Reference bits (e.g., ~LRU) in the Page Tables

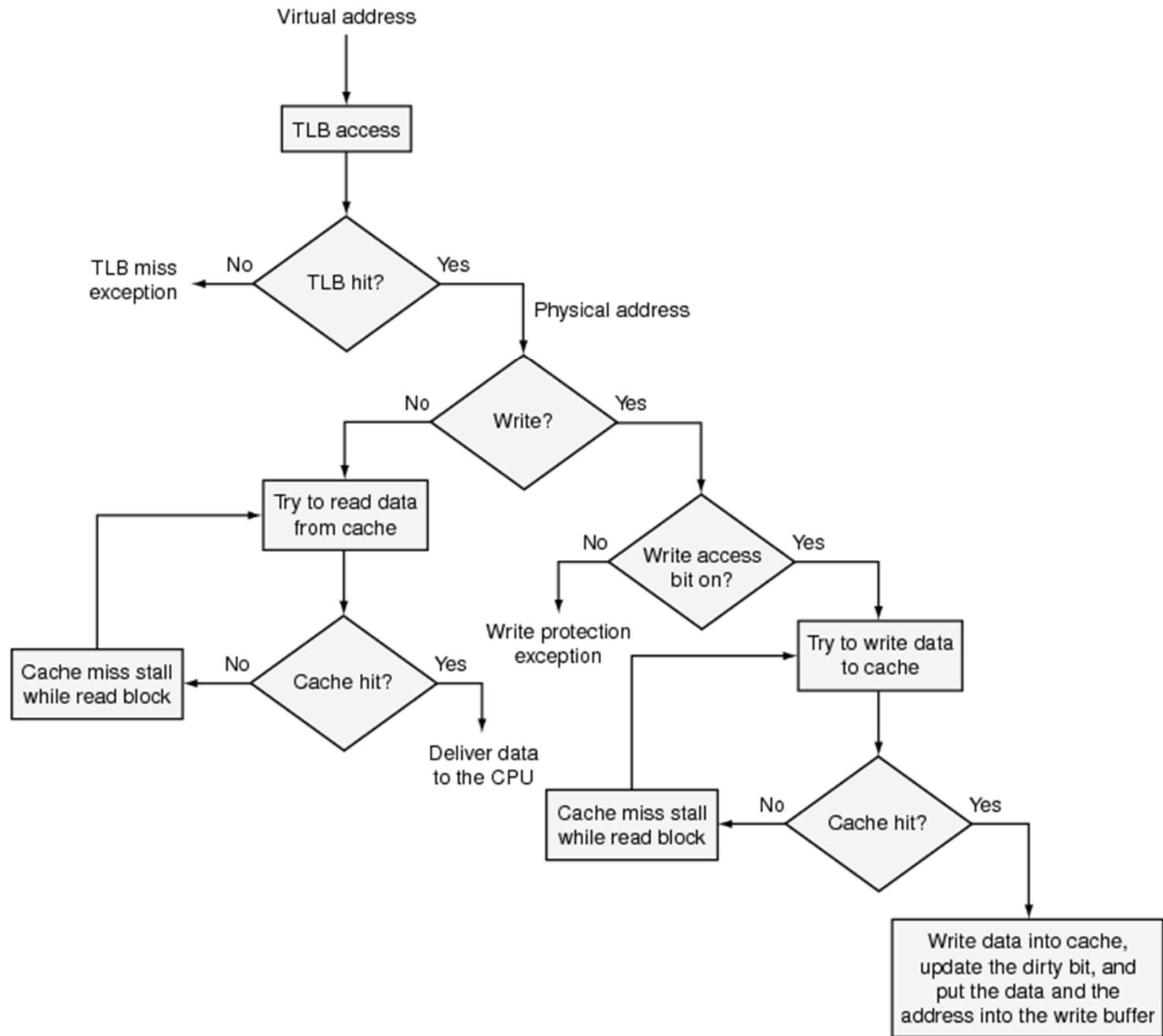

# Paging

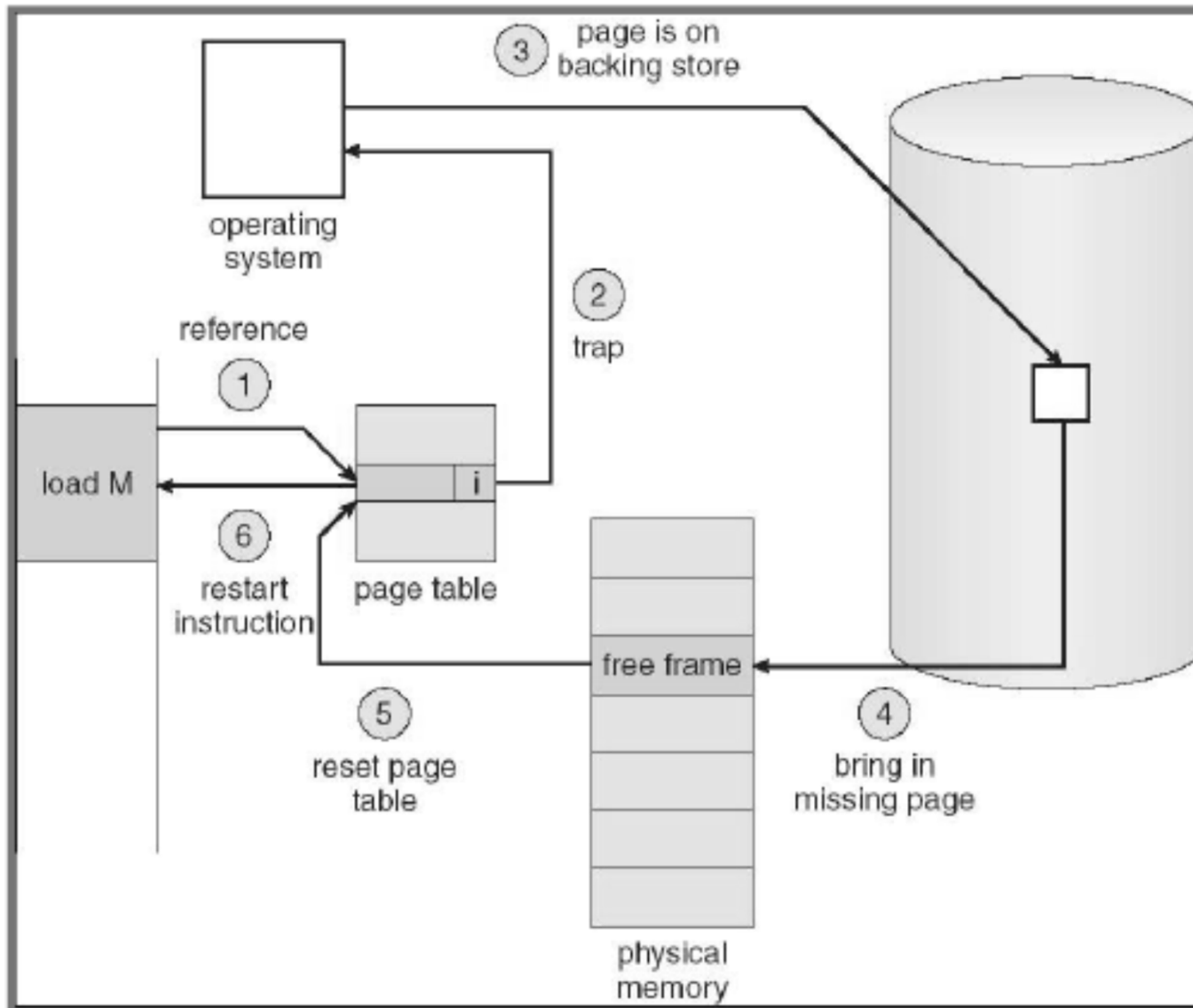



- 
- Traps, exceptions, and operating system

# Operating System

Some things not available to untrusted programs:

- Exception registers, HALT instruction, MMU instructions, talk to I/O devices, OS memory, ...

Need trusted mediator: Operating System (OS)

- *Safe control transfer*
- *Data isolation*

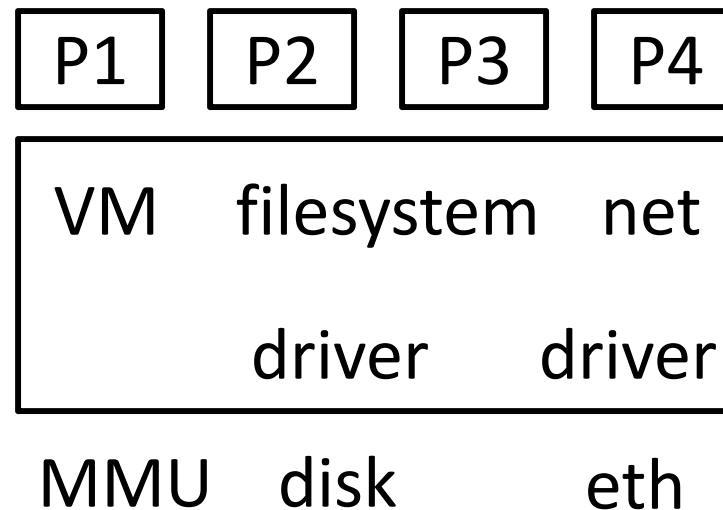

# Terminology

---

Trap: Any kind of a control transfer to the OS

Syscall: Synchronous (planned), program-to-kernel transfer

- SYSCALL instruction in MIPS (various on x86)

Exception: Synchronous, program-to-kernel transfer

- exceptional events: div by zero, page fault, page protection err, ...

Interrupt: Aysnchronous, device-initiated transfer

- e.g. Network packet arrived, keyboard event, timer ticks

\* real mechanisms, but nobody agrees on these terms

- 
- Multicore and Synchronization

- 
- Multi-core is a reality...
  - ... but how do we write multi-core safe code?



# Power Limits Performance

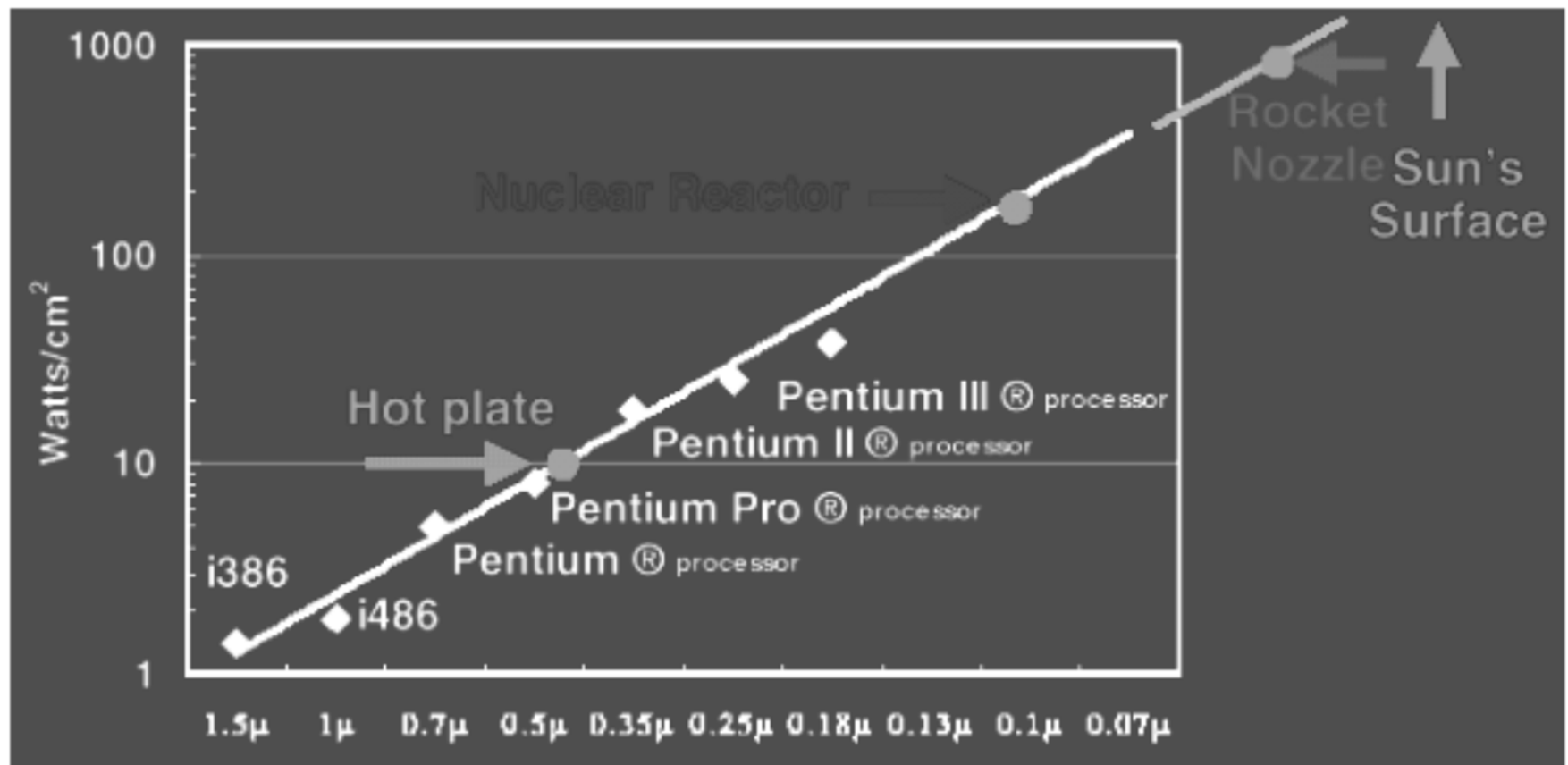

# Power Trends

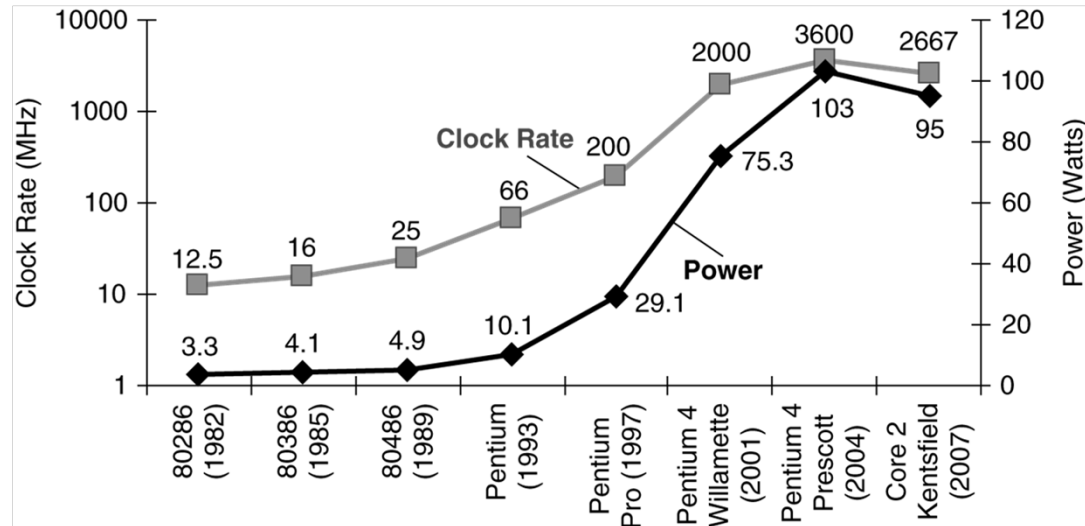

- In CMOS IC technology

$$\text{Power} = \text{Capacitive load} \times \text{Voltage}^2 \times \text{Frequency}$$

× 30

5V → 1V

× 1000



# Uniprocessor Performance

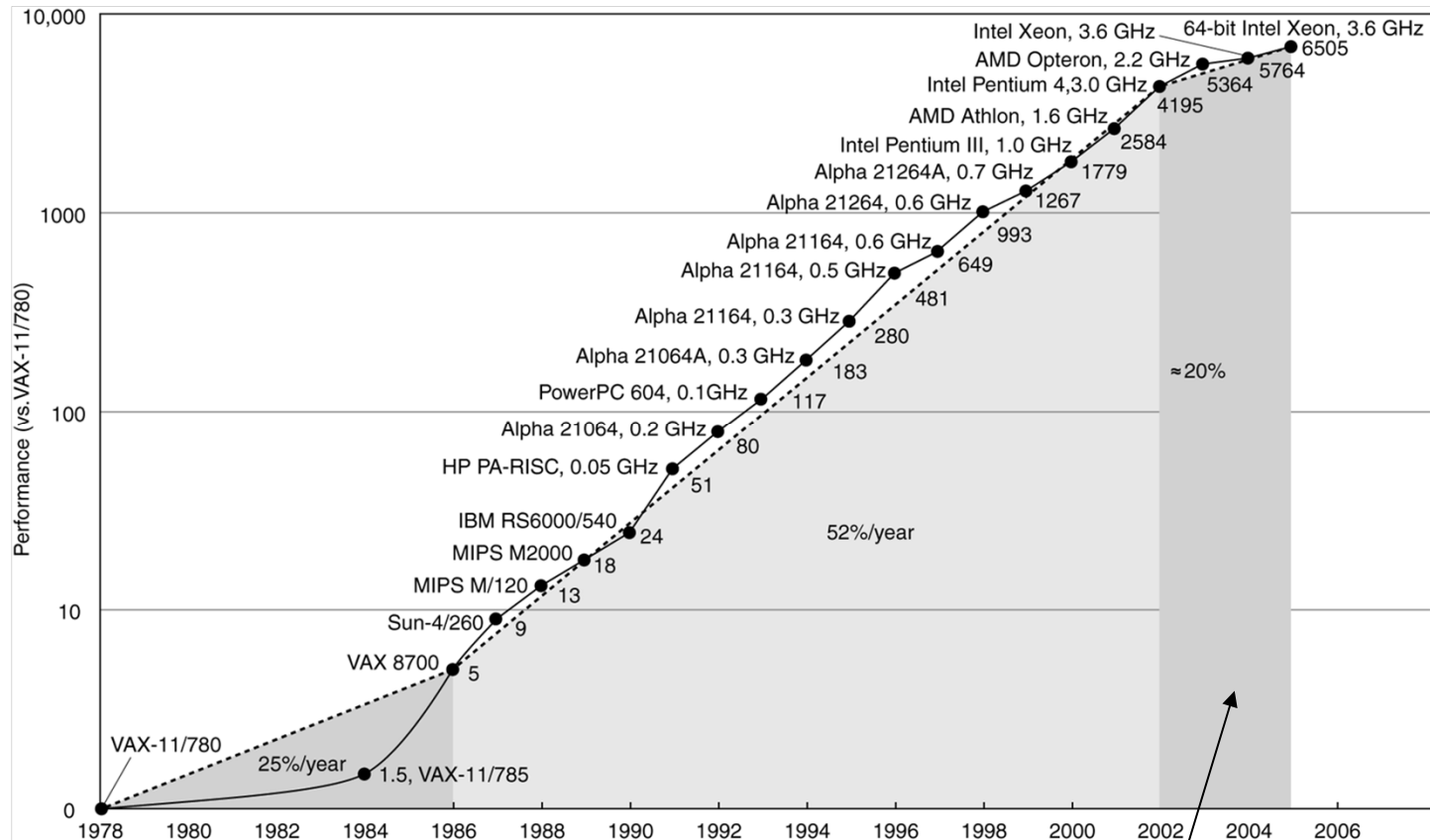

Constrained by power, instruction-level parallelism,  
memory latency

# Why Multicore?

---

- Moore's law
  - A law about transistors
  - Smaller means faster transistors
- Power consumption growing with transistors
- The power wall
  - We can't reduce voltage further
  - We can't remove more heat
- How else can we improve performance?

# Intel's argument

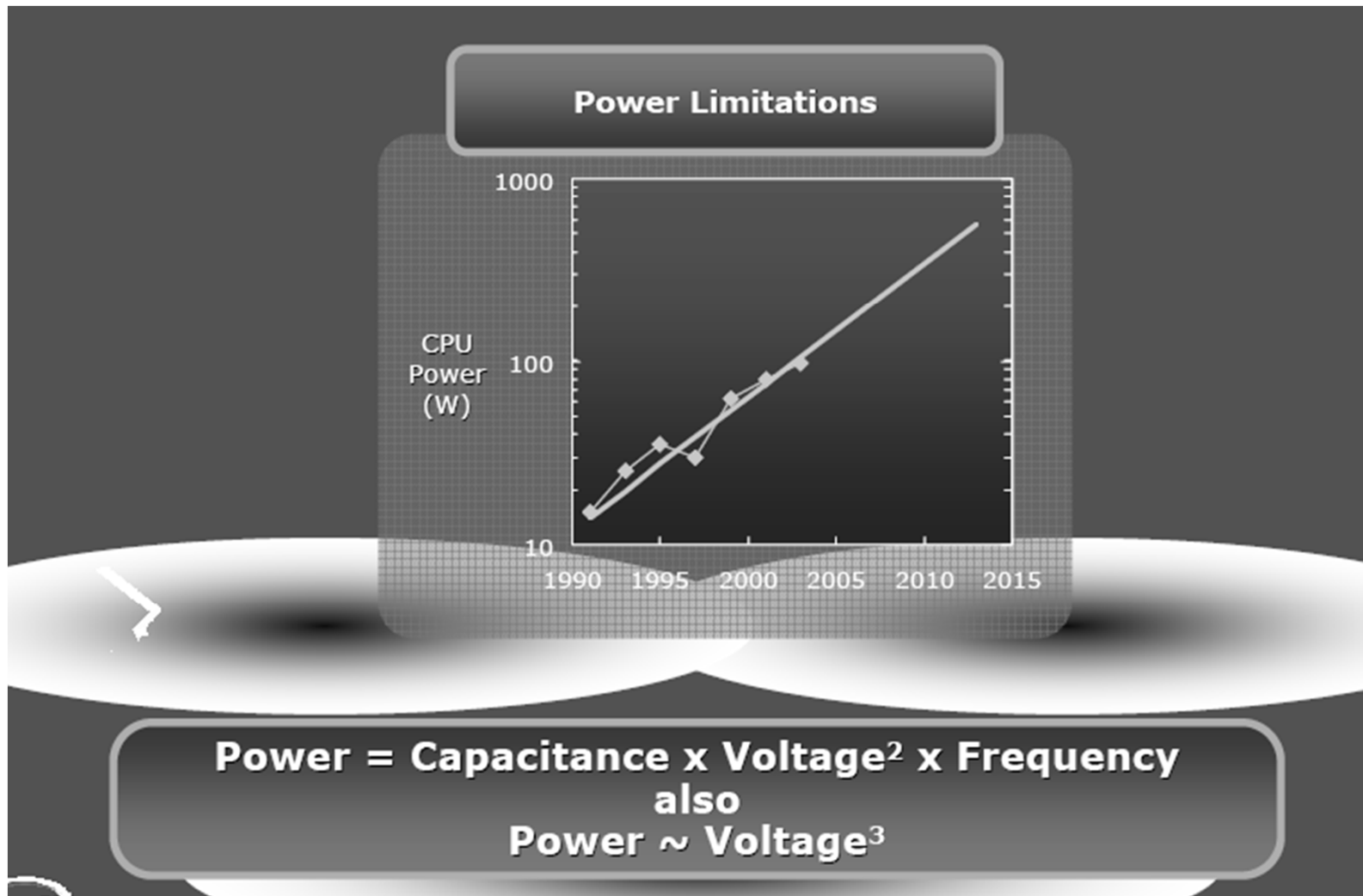

# Multi-Core Energy-Efficient Performance

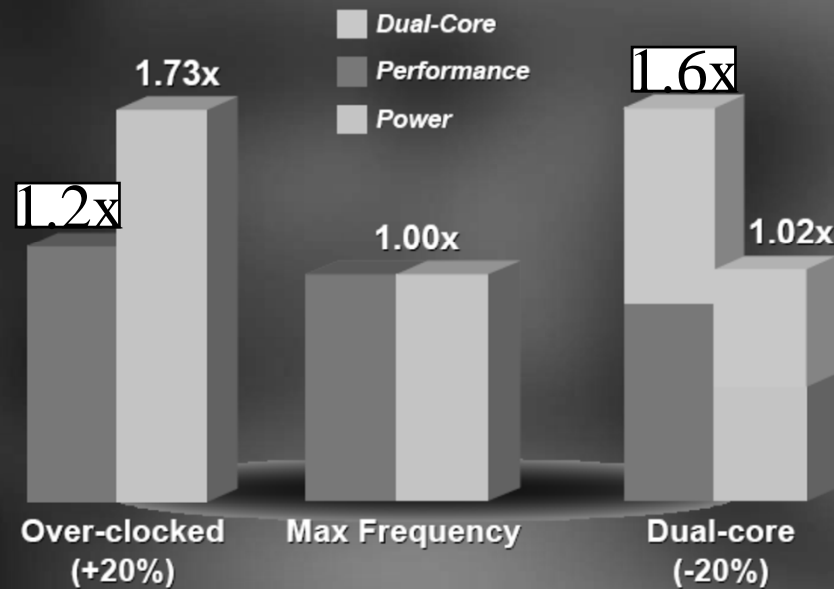

# Amdahl's Law

---

- Task: serial part, parallel part
- As number of processors increases,
  - time to execute parallel part goes to zero
  - time to execute serial part remains the same
- *Serial part eventually dominates*
- Must parallelize ALL parts of task

$$\text{Speedup}(E) = \frac{\text{Execution Time without } E}{\text{Execution Time with } E}$$

# Amdahl's Law

---

- Consider an improvement  $E$
- $F$  of the execution time is affected
- $S$  is the speedup

Execution time (with  $E$ ) =  $((1 - F) + F/S) \cdot$  Execution time (without  $E$ )

$$\text{Speedup (with } E) = \frac{1}{(1 - F) + F/S}$$

# Multithreaded Processes

---

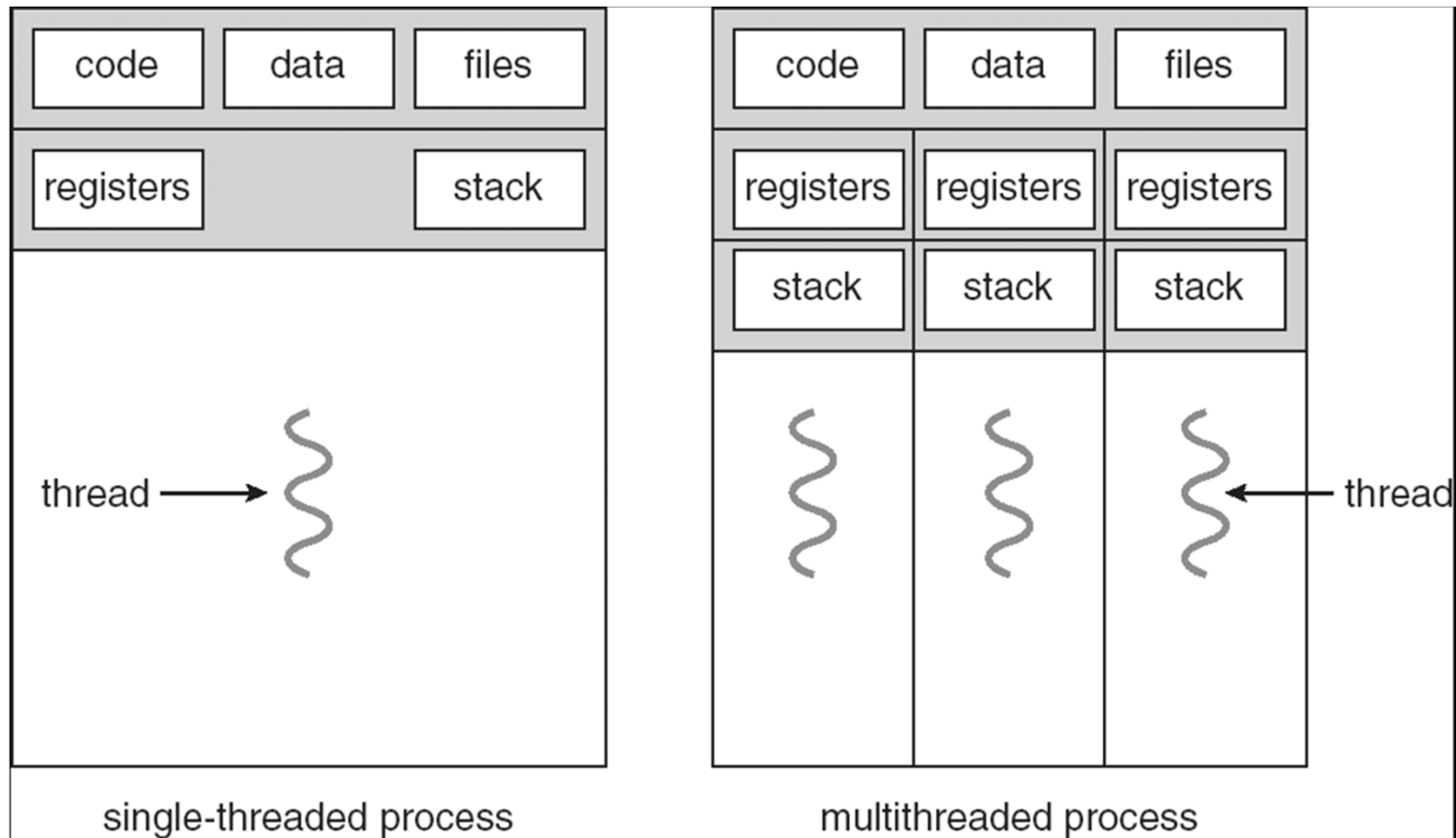

# Shared counters

---

- Usual result: works fine.
- Possible result: lost update!

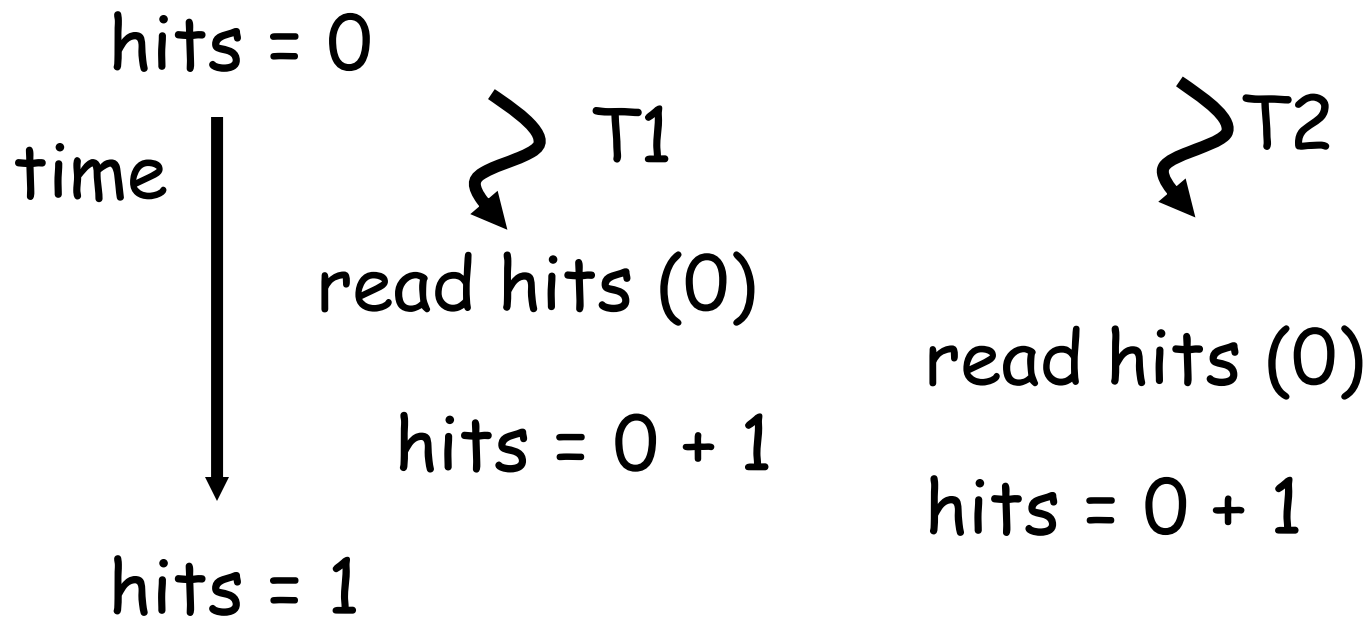

- Occasional timing-dependent failure  $\Rightarrow$  Difficult to debug
- Called a *race condition*



# Race conditions

---

- Def: a timing dependent error involving shared state
  - Whether it happens depends on how threads scheduled: who wins “races” to instructions that update state
  - Races are intermittent, may occur rarely
    - Timing dependent = small changes can hide bug
  - A program is correct *only* if *all possible* schedules are safe
    - Number of possible schedule permutations is huge
    - Need to imagine an adversary who switches contexts at the worst possible time

# Critical Sections

---

- Basic way to eliminate races: use *critical sections* that only one thread can be in
  - Contending threads must wait to enter

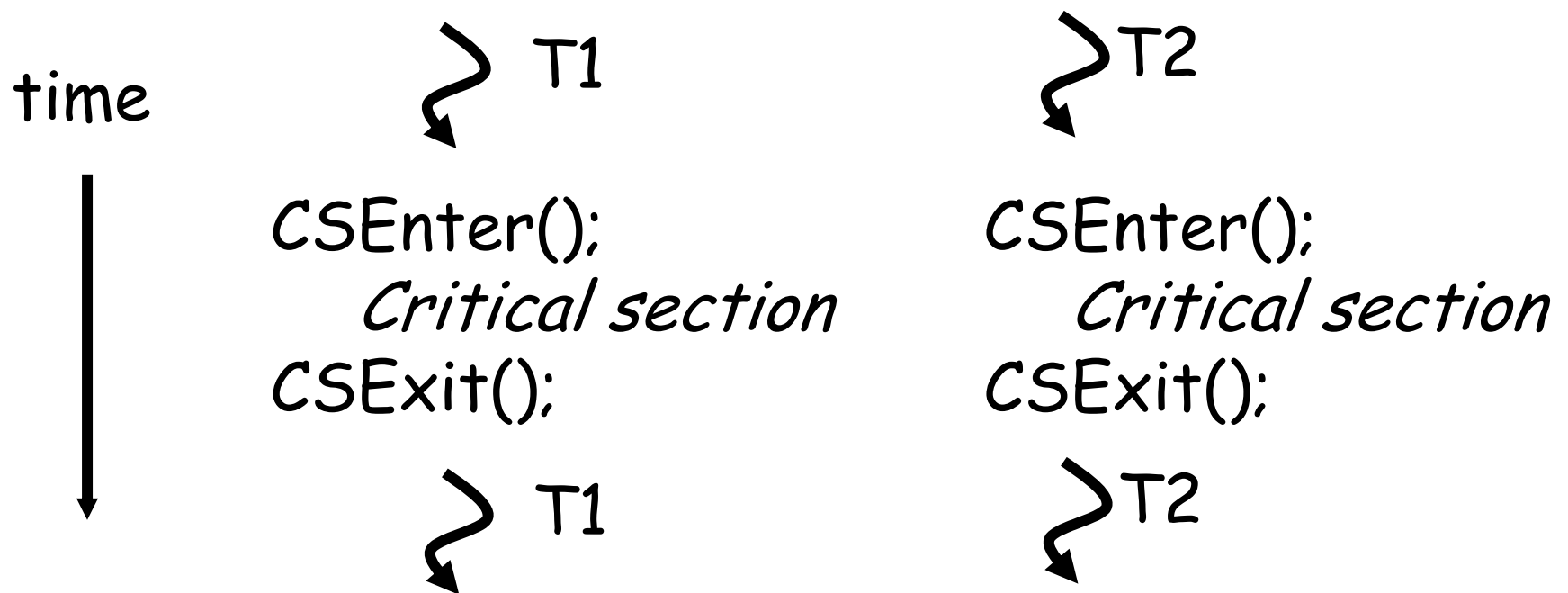

# Mutexes

---

- Critical sections typically associated with mutual exclusion locks (*mutexes*)
- Only one thread can hold a given mutex at a time
- Acquire (lock) mutex on entry to critical section
  - Or block if another thread already holds it
- Release (unlock) mutex on exit
  - Allow one waiting thread (if any) to acquire & proceed

```
pthread_mutex_init(m);  
pthread_mutex_lock(m);    pthread_mutex_lock(m);  
    hits = hits+1;        hits = hits+1;  
pthread_mutex_unlock(m);  pthread_mutex_unlock(m);
```

↪ T1

↪ T2

# Protecting an invariant

---

// invariant: data is in buffer[first..last-1]. Protected by m.

```
pthread_mutex_t *m;
```

```
char buffer[1000];
```

```
int first = 0, last = 0;
```

```
void put(char c) {  
    pthread_mutex_lock(m);  
    buffer[last] = c;  
    last++;  
    pthread_mutex_unlock(m);  
}
```

```
char get() {  
    pthread_mutex_lock(m);  
    char c = buffer[first];  
    first++;      X what if first==last?  
    pthread_mutex_unlock(m);  
}
```

- Rule of thumb: all updates that can affect invariant become critical sections.

---

See you Tonight  
Good Luck!